



USER MANUAL

BEDIENUNGSANLEITUNG

INSTRUKCJA OBSŁUGI

NÁVOD K POUŽITÍ

MANUEL D'UTILISATION

ISTRUZIONI PER L'USO

MANUAL DE INSTRUCCIONES

HASZNÁLATI ÚTMUTATÓ

BRUGSANVISNING

KÄYTTÖOHJE

GEBRUIKSAANWIJZING

BRUKSANVISNING

INSTRUÇÕES DE UTILIZAÇÃO

POUŽÍVATELSKÁ PRÍRUČKA

РЪКОВОДСТВО ЗА УПОТРЕБА

ΟΔΗΓΙΕΣ ΧΡΗΣΗΣ

UPUTE ZA UPORABU

NAUDOJIMO INSTRUKCIJA

MANUAL DE UTILIZARE

NAVODILA ZA UPORABO

METAL TOOL SHED



This User Manual has been translated using machine translation. We have made every effort to ensure the translation is accurate, but please note that automated translations are not perfect and are not meant to replace human translators. The official version of the User Manual is in English. Any differences between the translated version and the original English are not legally binding. If you have any questions about the accuracy of the translation, please refer to the English version, which is the official reference. More language versions are available upon request via info@expondo.com.



Niniejsza instrukcja obsługi została przetłumaczona za pomocą tłumaczenia maszynowego. Dołożyliśmy wszelkich starań, aby zapewnić dokładność tłumaczenia. Należy jednak pamiętać, że tłumaczenia automatyczne nie są doskonałe i nie mają na celu zastąpienia tłumacza. Oficjalna wersja instrukcji obsługi jest w języku angielskim. Wszelkie różnice między wersją przetłumaczoną a oryginałem w języku angielskim nie są prawnie wiążące. Jeśli masz jakiegokolwiek pytania dotyczące dokładności tłumaczenia, zapoznaj się z wersją angielską, która jest wersją oficjalną. Więcej wersji językowych jest dostępnych na życzenie pod adresem info@expondo.com.

CONTENT | TREŚĆ

PRODUCT NAME	METAL TOOL SHED
NAZWA PRODUKTU	METALOWY DOMEK OGRODOWY, SZOPA
PRODUCT MODEL	UNI_SHED_01
MODEL PRODUKTU	
MANUFACTURER	EXPONDO POLSKA SP. Z O.O. SP. K.
PRODUCENT	
MANUFACTURER ADDRESS	UL. NOWY KISIELIN-INNOWACYJNA 7, 66-002 ZIELONA GÓRA POLAND, EU
ADRES PRODUCENTA	

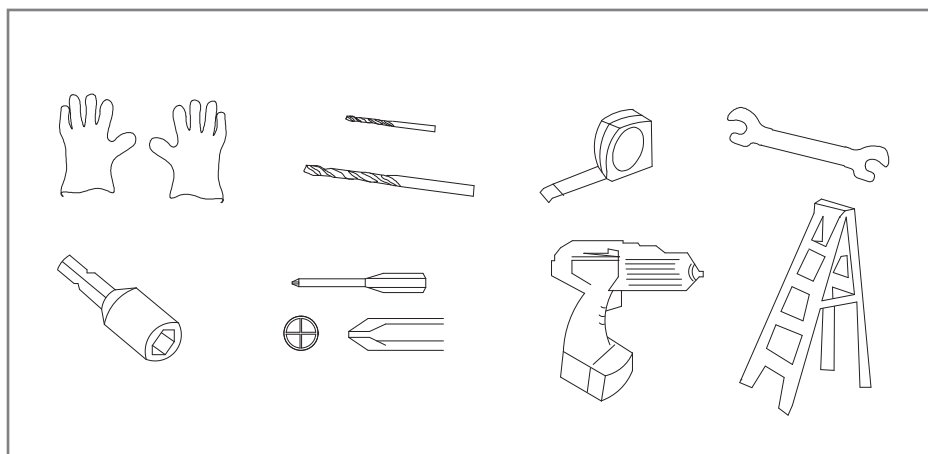

SAFETY INSTRUCTIONS

DO NOT USE THE DEVICE UNLESS YOU HAVE THOROUGHLY READ AND UNDERSTOOD THIS USER MANUAL.

Warning: Read all safety warnings and instructions. Failure to follow the warnings and instructions may result in serious injury.

1. General Safety

This product is for the intended use only.

Do not use the product for purposes other than those described in this manual.

Keep this manual for future reference.

2. Operational Safety

Use the product only on a stable, level surface.

Do not operate the product if it is damaged or malfunctioning.

Keep away from children and pets.

3. Maintenance Safety

Only qualified personnel should perform repairs.

Use only original spare parts.

4. Warning Symbols

Caution: Indicates a potentially hazardous situation which, if not avoided, could result in minor or moderate injury.

Warning: Indicates a potentially hazardous situation which, if not avoided, could result in death or serious injury.

Potential risks and hazards: Lists all risks and hazards directly or indirectly connected with the use or misuse of the product.

INSTRUKCJE BEZPIECZEŃSTWA

NIE UŻYWAJ URZĄDZENIA, DOPÓKI DOGŁĘBNIĘ NIE PRZECZYTAJesz I NIE ZROZUMIESZ TEJ INSTRUKCJI OBSŁUGI.

Ostrzeżenie: Przeczytaj wszystkie ostrzeżenia i instrukcje bezpieczeństwa. Nieprzestrzeganie zaleceń może spowodować poważne obrażenia.

1. Bezpieczeństwo ogólne

Ten produkt przeznaczony jest wyłącznie do użytku zgodnego z instrukcją.

Nie używaj produktu do celów innych niż opisane w niniejszej instrukcji.

Zachowaj instrukcję do przyszłych odniesień.

2. Bezpieczeństwo podczas użytkowania

Używaj produktu tylko na stabilnej, równej powierzchni.

Nie uruchamiaj produktu, jeśli jest uszkodzony lub działa nieprawidłowo.

Trzymaj z dala od dzieci i zwierząt.

3. Bezpieczeństwo konserwacji

Naprawy może przeprowadzać wyłącznie wykwalifikowany personel.

Używaj wyłącznie oryginalnych części zamiennych.

4. Symbole ostrzegawcze

Ostrożność: Wskazuje sytuację potencjalnie niebezpieczną, której niezastosowanie się może spowodować drobne lub umiarkowane obrażenia.

Ostrzeżenie: Wskazuje sytuację potencjalnie niebezpieczną, której niezastosowanie się może spowodować śmierć lub poważne obrażenia.

Potencjalne ryzyka i zagrożenia: Wymieniono wszystkie ryzyka i zagrożenia bezpośrednio lub pośrednio związane z użytkowaniem lub niewłaściwym użyciem produktu.

MAINTENANCE AND CLEANING

1. Regular Maintenance
Inspect the product regularly for signs of wear or damage.
Replace any damaged parts immediately.
2. Cleaning
Use a soft, damp cloth to clean the exterior.
Do not use abrasive cleaners or solvents.
3. Storage
Store in a cool, dry place.
Protect from dust and moisture.

DISPOSAL

- Do not dispose of this product as unsorted municipal waste.
- By ensuring proper disposal, you help prevent potential negative consequences for the environment and human health.

DECLARATION OF COMPLIANCE

We, expondo Polska sp. z o.o. sp. k., declare under our sole responsibility that the [Metal tool shed], Model [UNI_SHED_01], to which this declaration relates, is in conformity with the relevant Union harmonization legislation:

- Regulation (EU) 2023/988 (General Product Safety Regulation)

KONSERWACJA I CZYSZCZENIE

1. Regular Maintenance
Inspect the product regularly for signs of wear or damage.
Replace any damaged parts immediately.
2. Cleaning
Use a soft, damp cloth to clean the exterior.
Do not use abrasive cleaners or solvents.
3. Storage
Store in a cool, dry place.
Protect from dust and moisture.











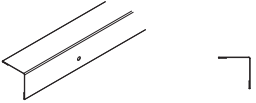
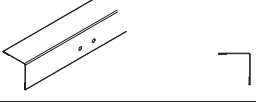

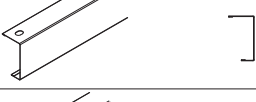

UTYLIZACJA





- Nie wyrzucaj tego produktu jako zmieszanych odpadów komunalnych.
- Właściwa utylizacja pomaga zapobiec potencjalnym negatywnym konsekwencjom dla środowiska i zdrowia ludzi.





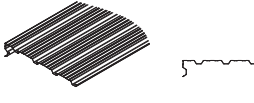
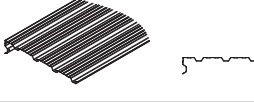
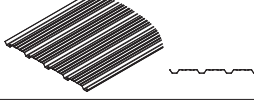
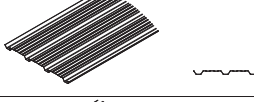
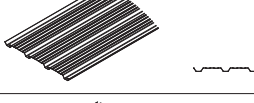
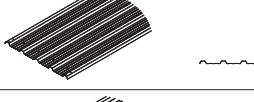
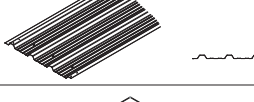
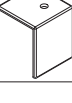
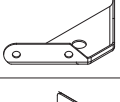
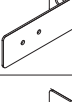
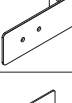
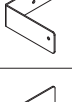

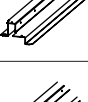
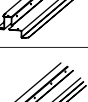
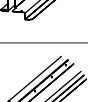

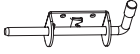

DEKLARACJA ZGODNOŚCI





My, expondo Polska sp. z o.o. sp. k., oświadczamy wyłączną odpowiedzialnością, że **[Metal tool shed], Model [UNI_SHED_01]**, do którego odnosi się niniejsza deklaracja, jest zgodny z odpowiednimi unijnymi przepisami harmonizacyjnymi:

- Rozporządzenie (UE) 2023/988 (Rozporządzenie w sprawie ogólnego bezpieczeństwa produktów).



NO.	PART	Qty.
9L		1
9R		1
10		1
12		1
15		1
16		1
17		2
20		4
25L		1
25R		1
DLA		1
DLB		1
DRA		1
DRB		1
DX1		4

NO.	PART	Qty.
P2L		1
P2R		1
P3		3
P3L		1
P3R		1
P5		1
P7		3
GC		4
JM5		4
JM6		1
JM7		1
JM8		1
JM9		1
1		1
2		1
3		1
4		1

NO.	PART	Qty.
DC		1
DH		4
DF		1
DG		1
F3		32
F4		5
F1		164
F2		8
S1		50
S2		126

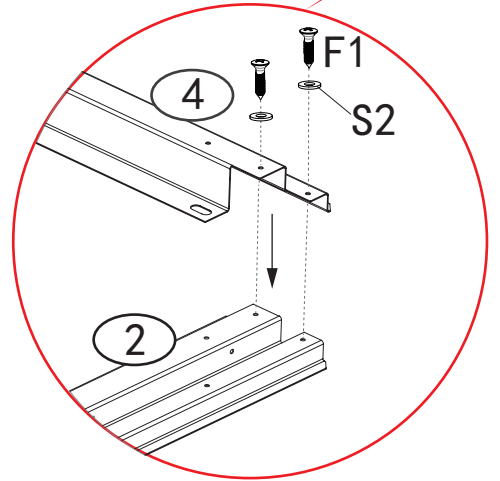
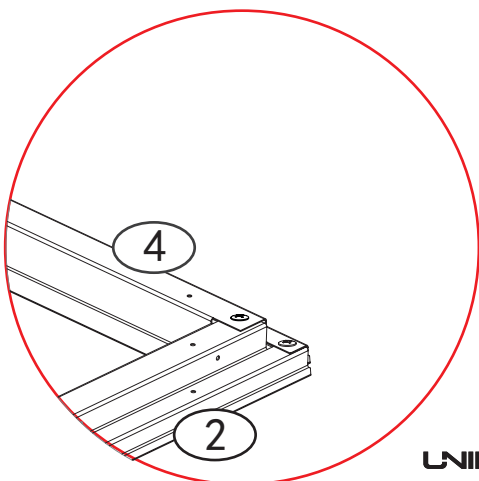
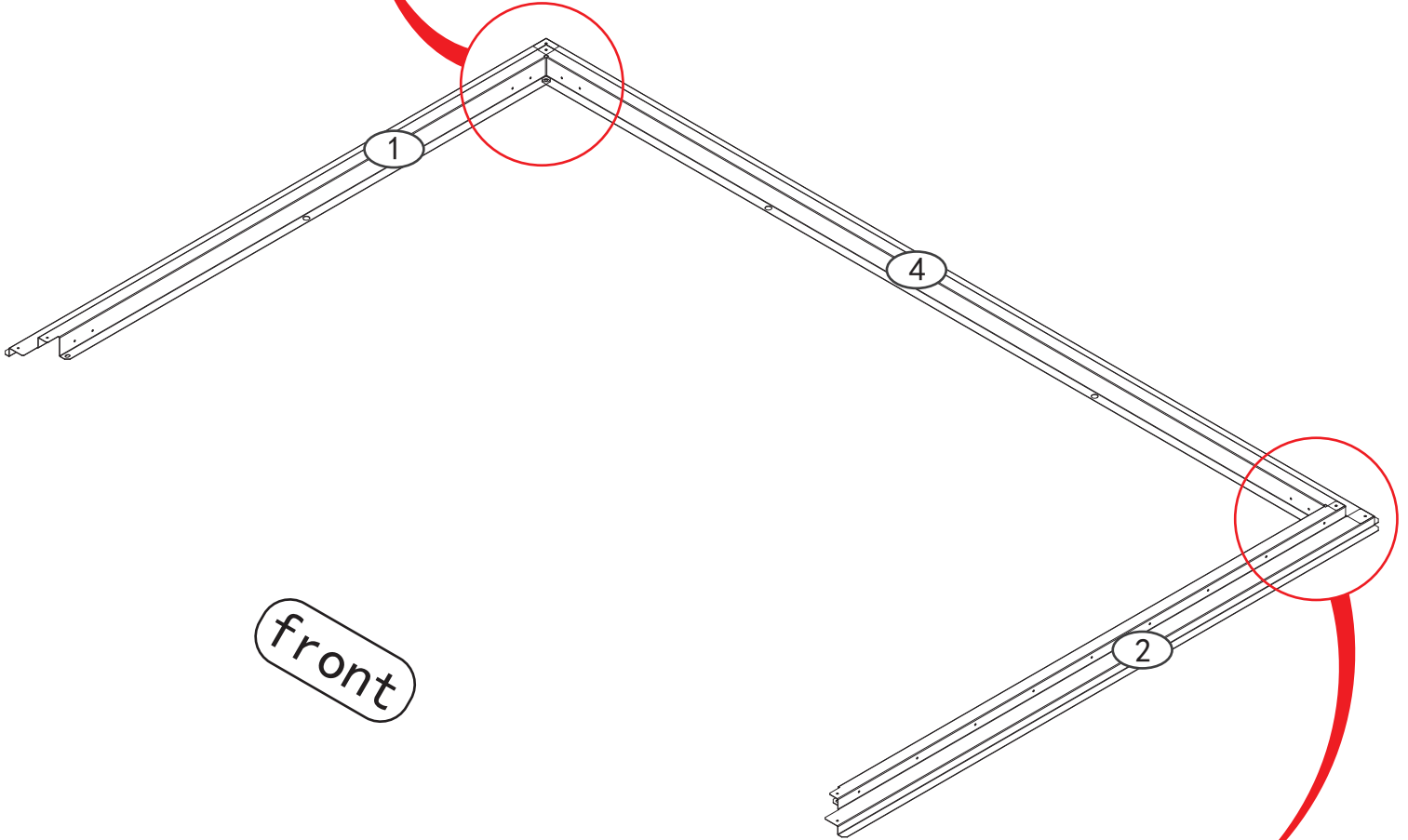
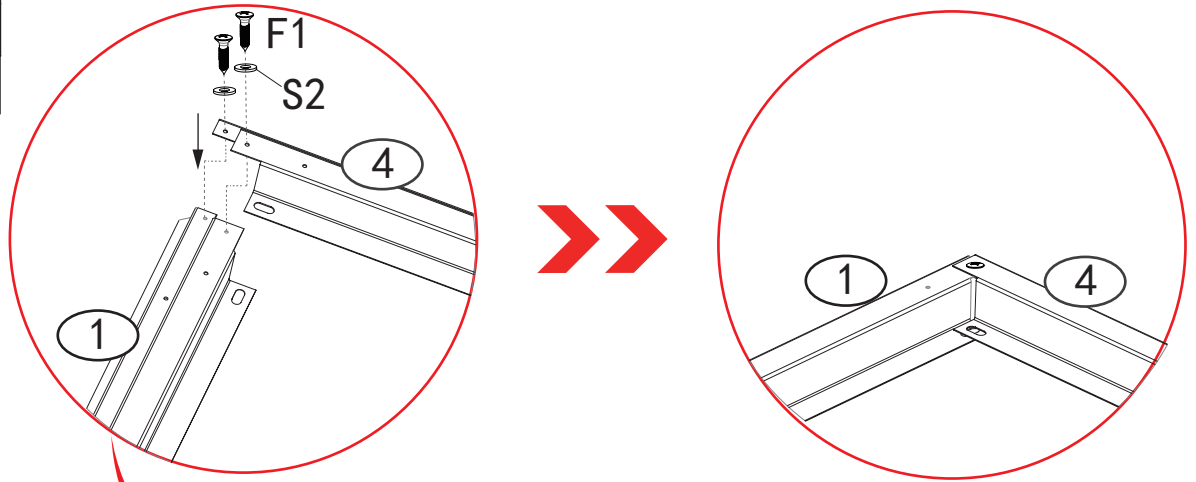

Parts	No.	Qty.
	1	1
	4	1
	2	1
	F1	4
	S2	4





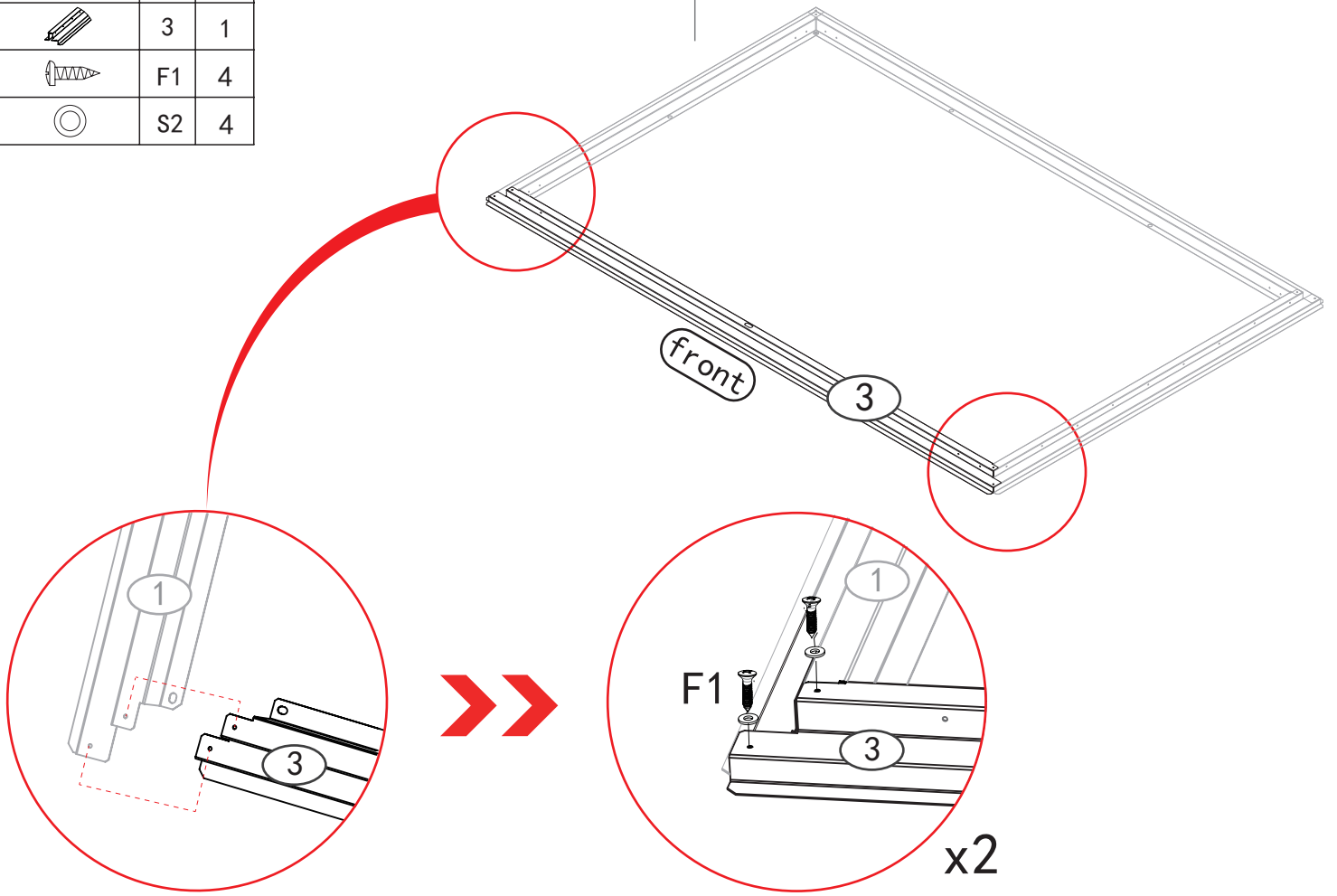

Parts	No.	Qty.
	3	1
	F1	4
	S2	4

9

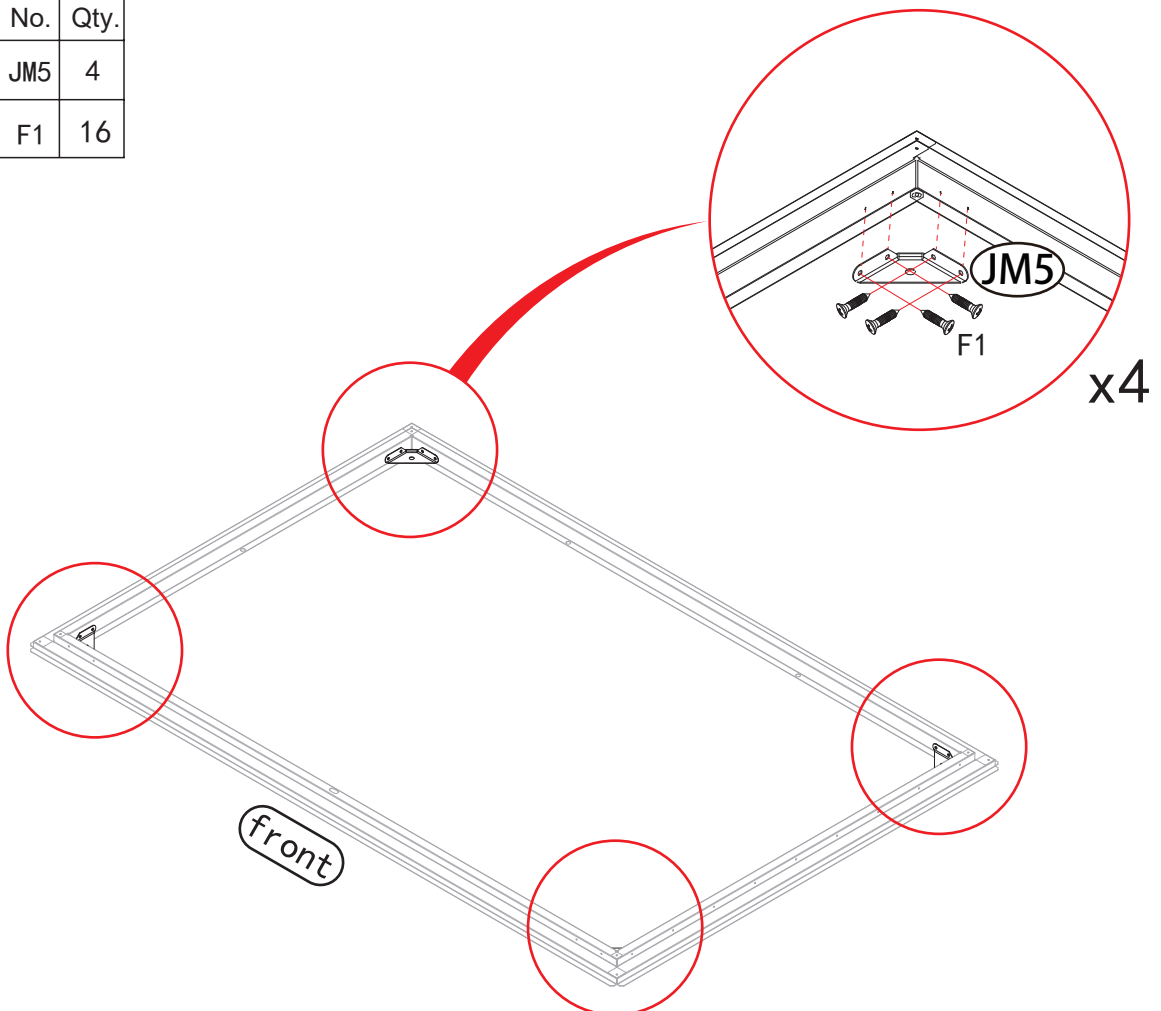

Parts	No.	Qty.
	JM5	4
	F1	16





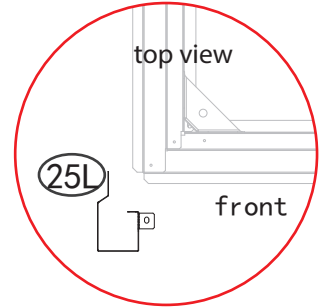
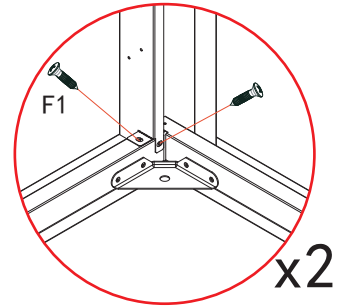
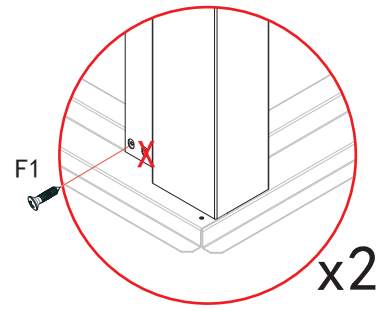
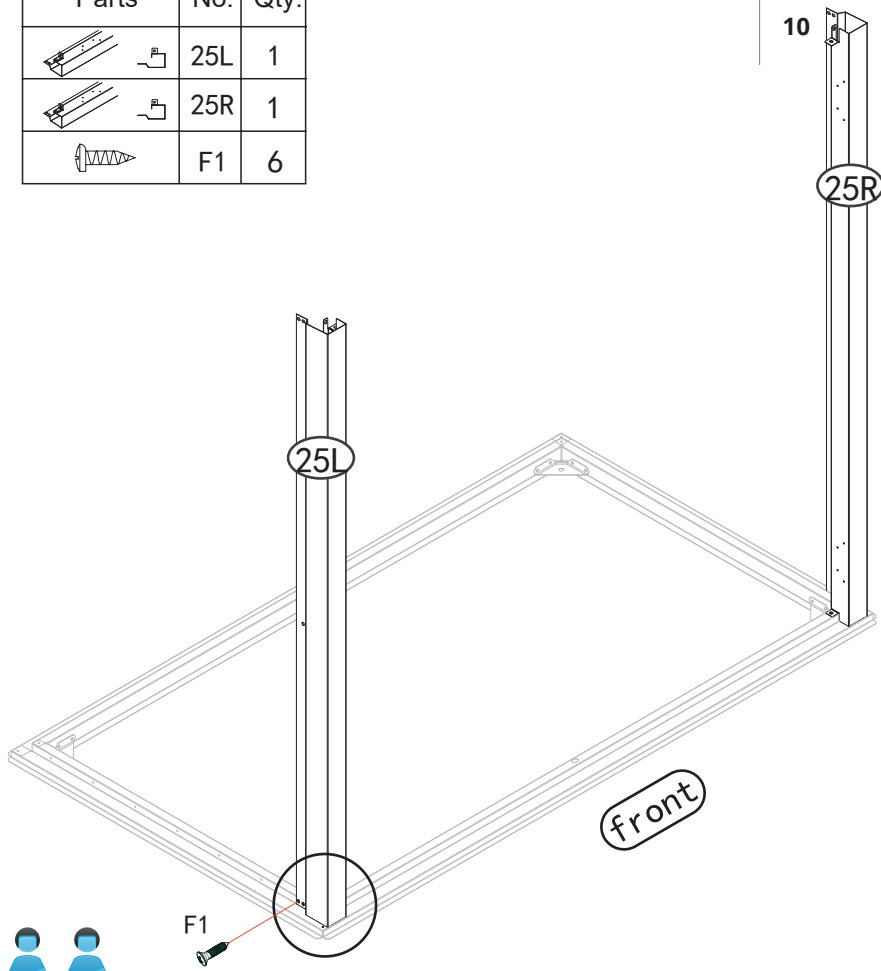

Parts	No.	Qty.
	25L	1
	25R	1
	F1	6

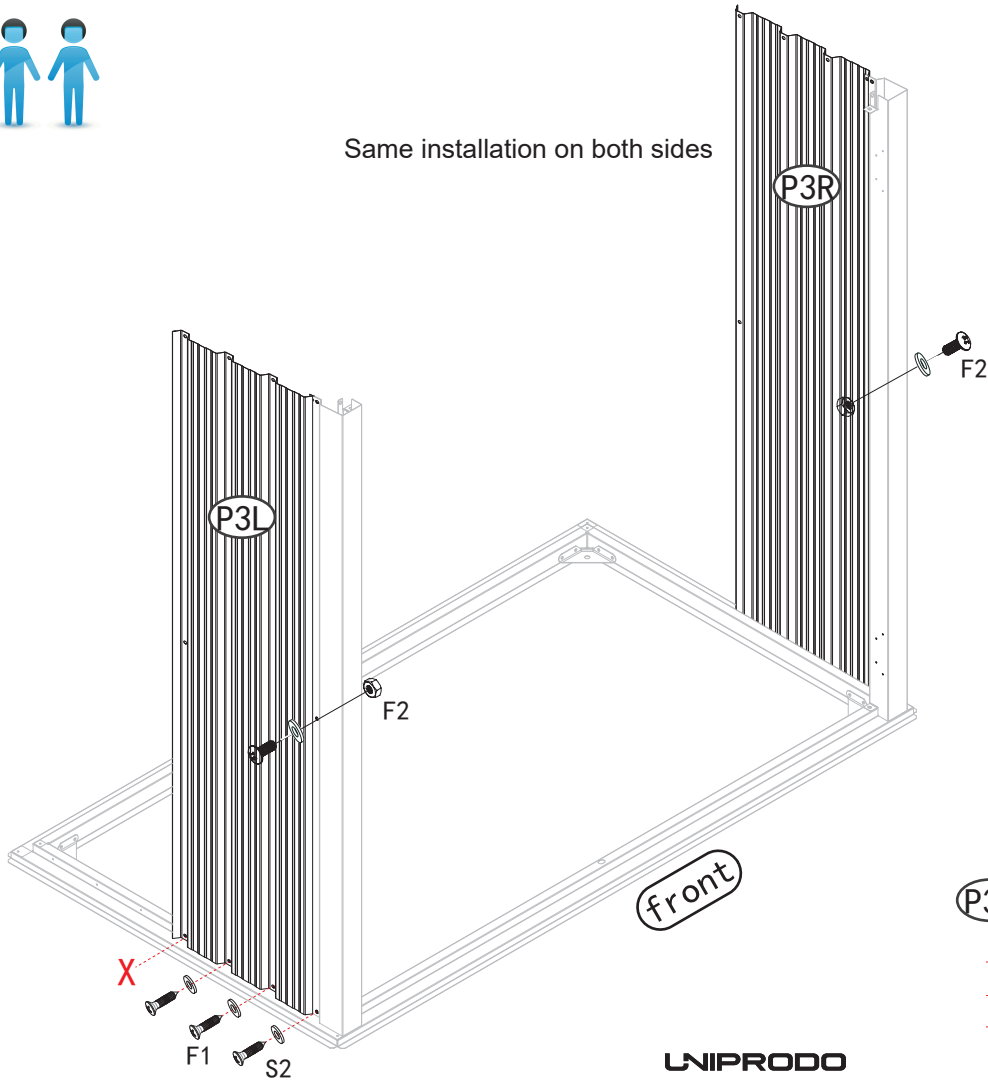

Same installation on both sides



Parts	No.	Qty.
	P3L	1
	P3R	1
	F1	6
	S2	8
	F2	2

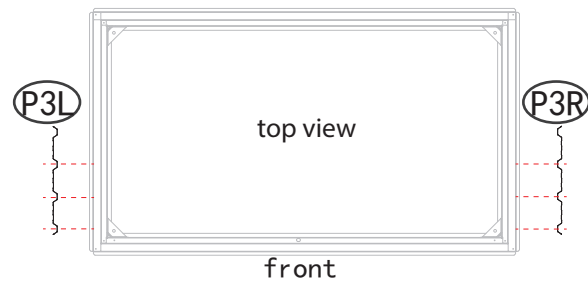

LNIPRODO

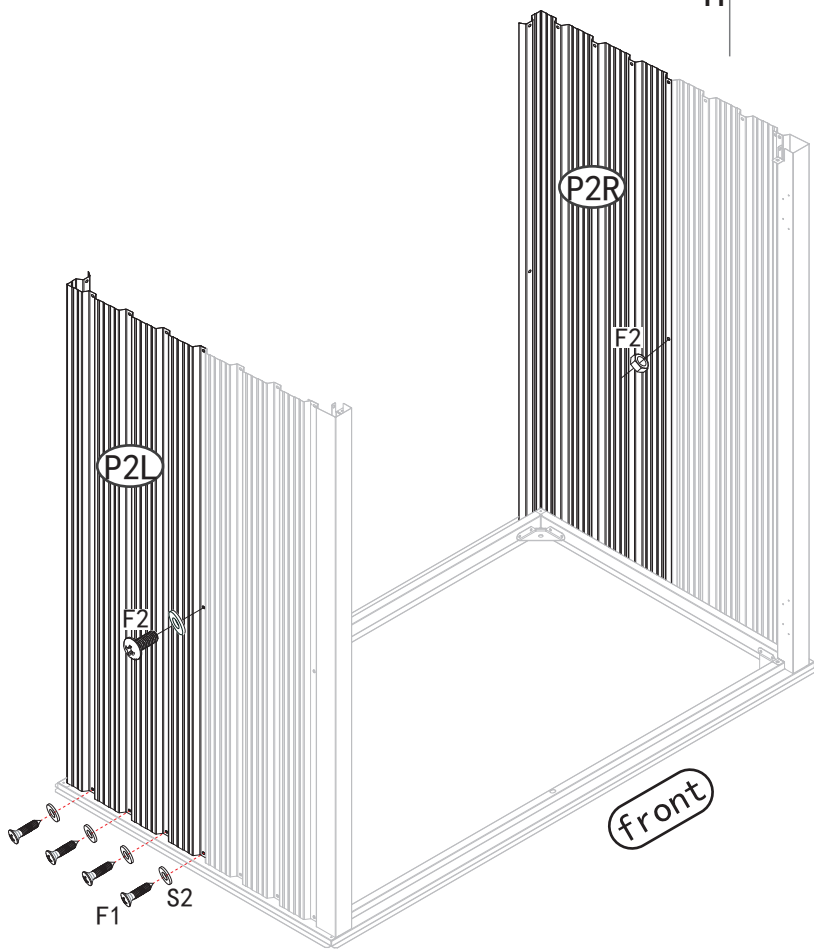



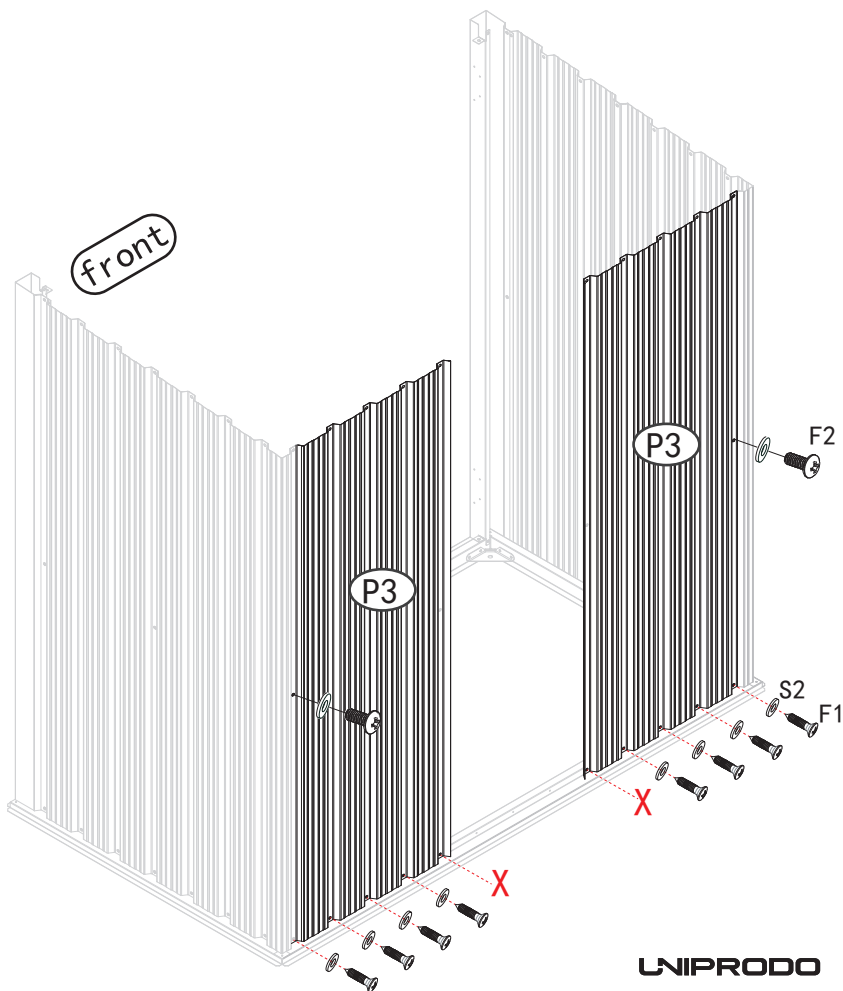
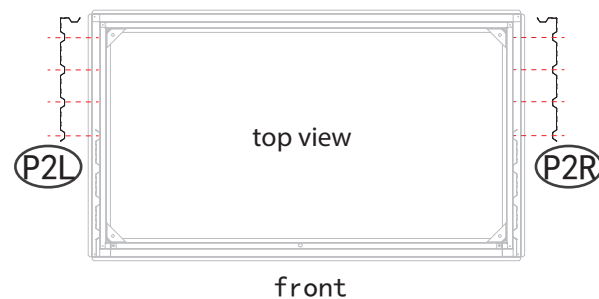

Parts	No.	Qty.
	P2L	1
	P2R	1
	F1	8
	S2	10
	F2	2

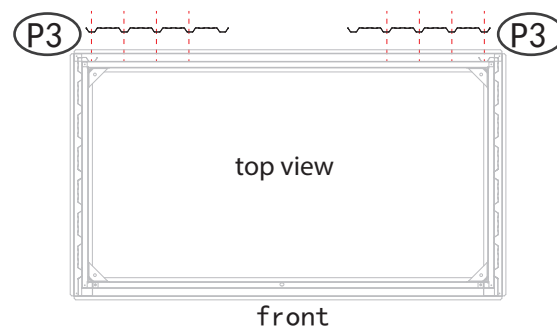







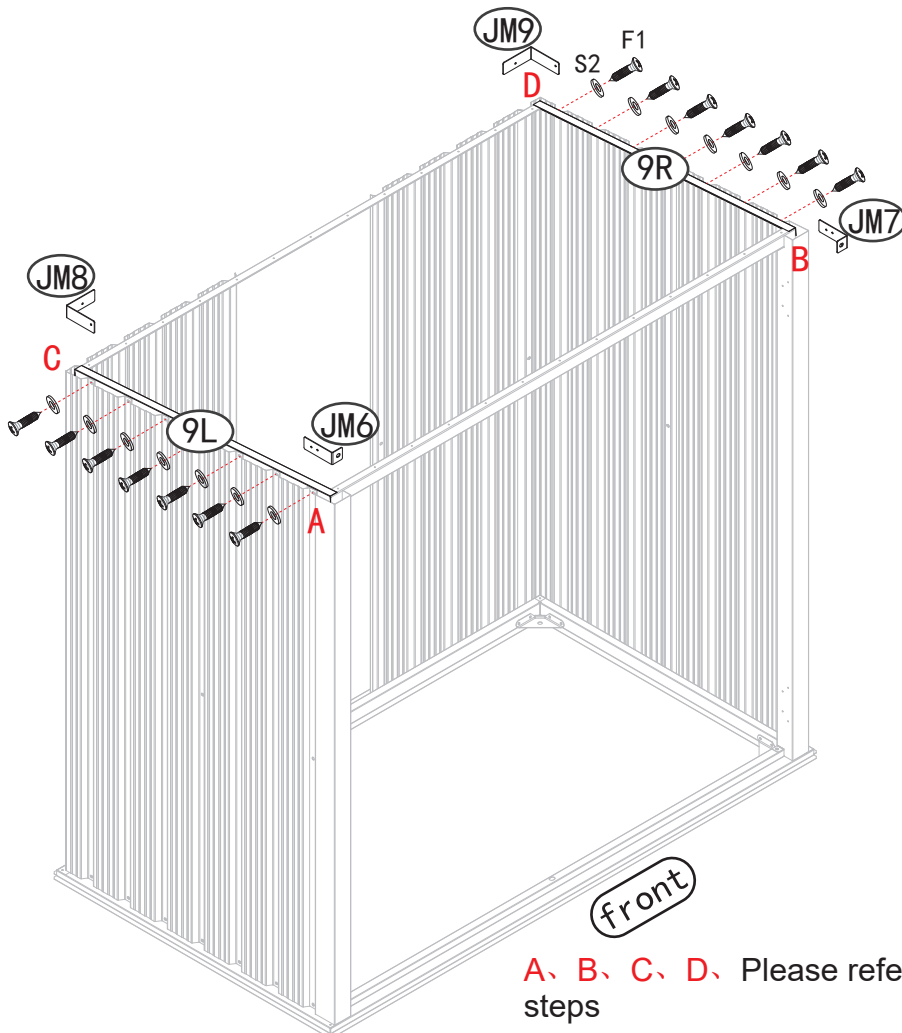
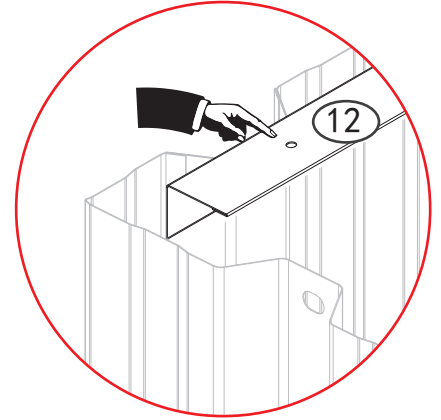
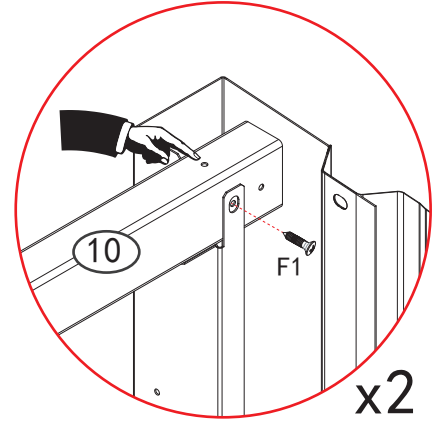
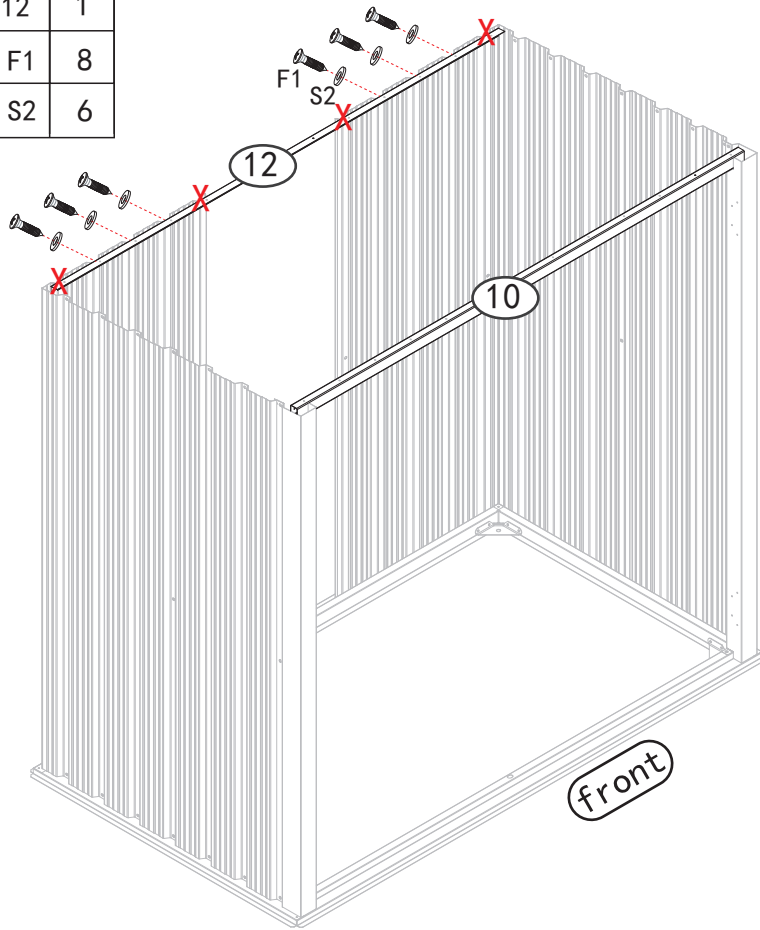

Parts	No.	Qty.
	P3	2
	F1	8
	S2	10
	F2	2



Parts	No.	Qty.
	10	1
	12	1
	F1	8
	S2	6

12



NO.	PART	Qty.
9L		1
9R		1
JM6		1
JM7		1
JM8		1
JM9		1
F1		24
S2		24

A, B, C, D. Please refer to the next page for detailed installation steps

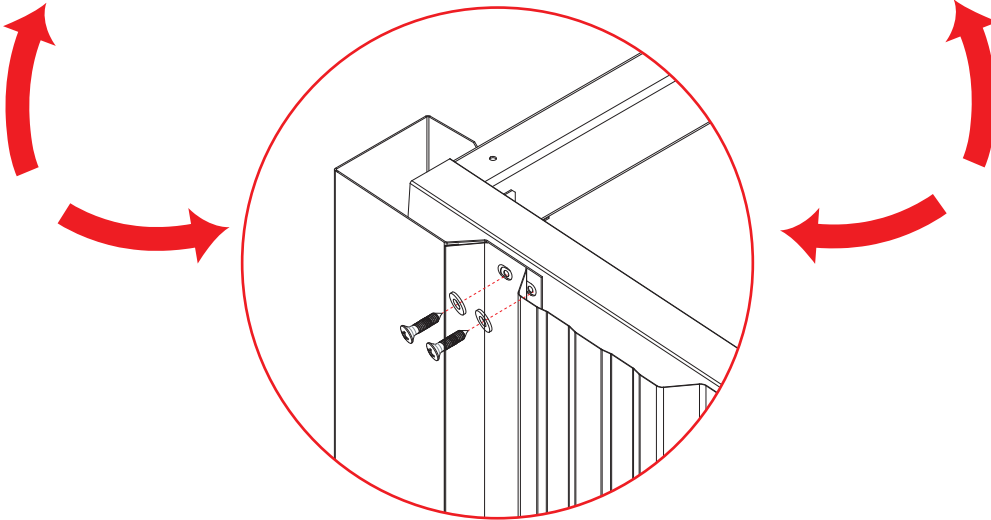
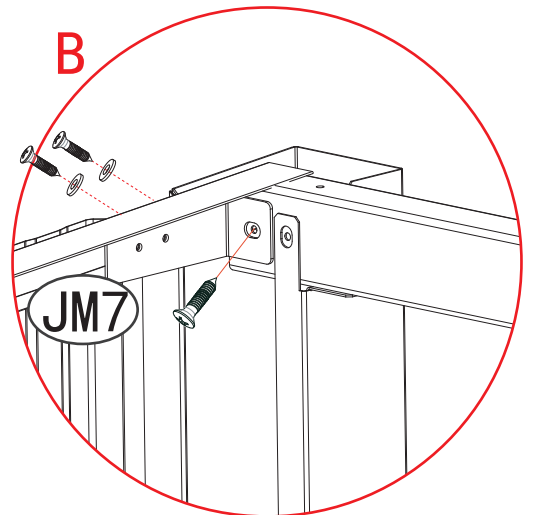
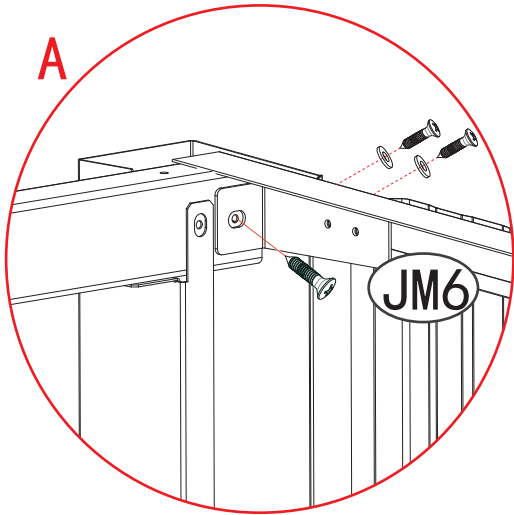

You can choose to install one F1 here, or you can choose to install two F1.

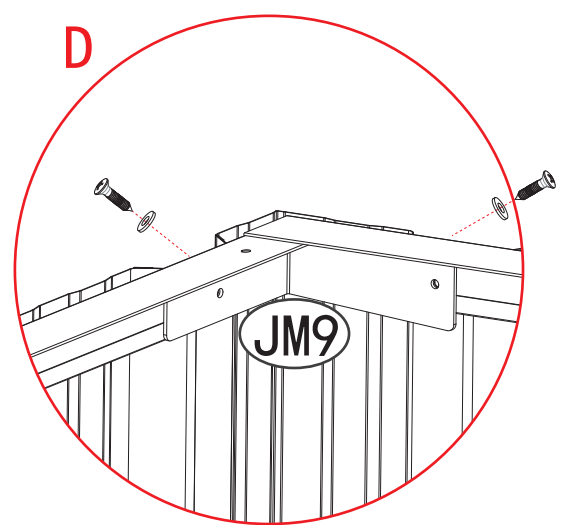
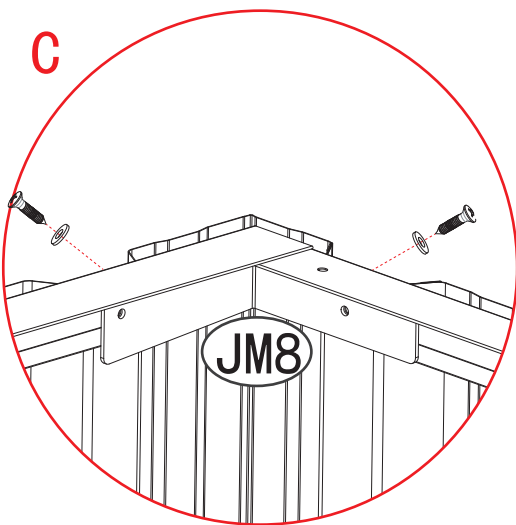

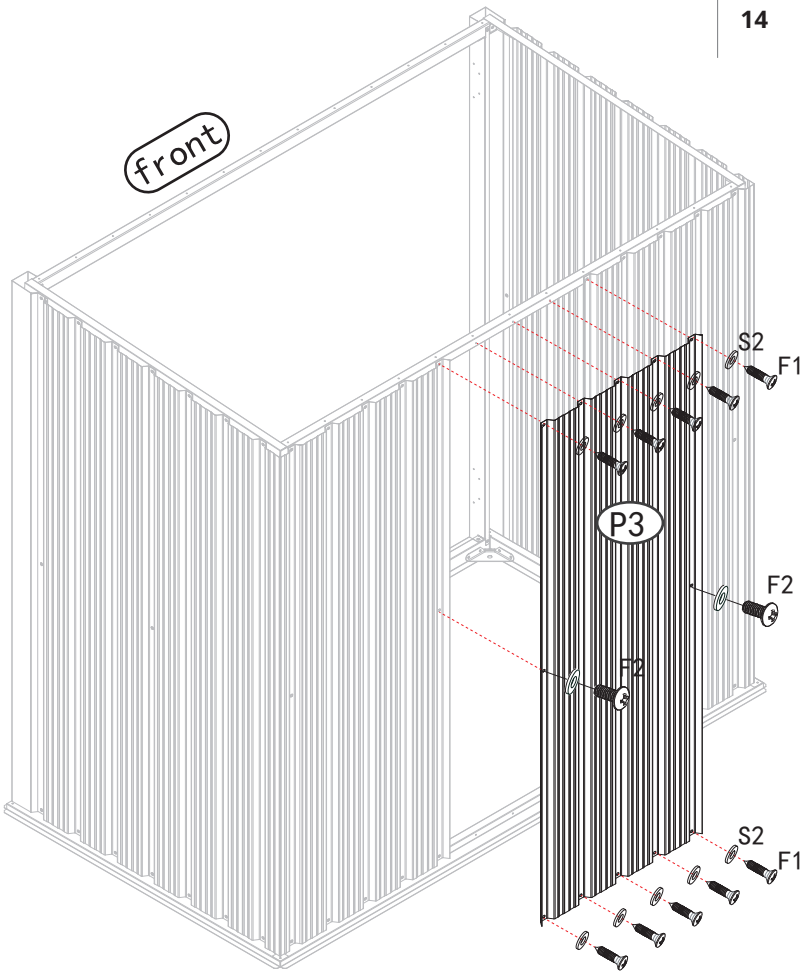

Parts	No.	Qty.
	P3	1
	F1	10
	S2	12
	F2	2

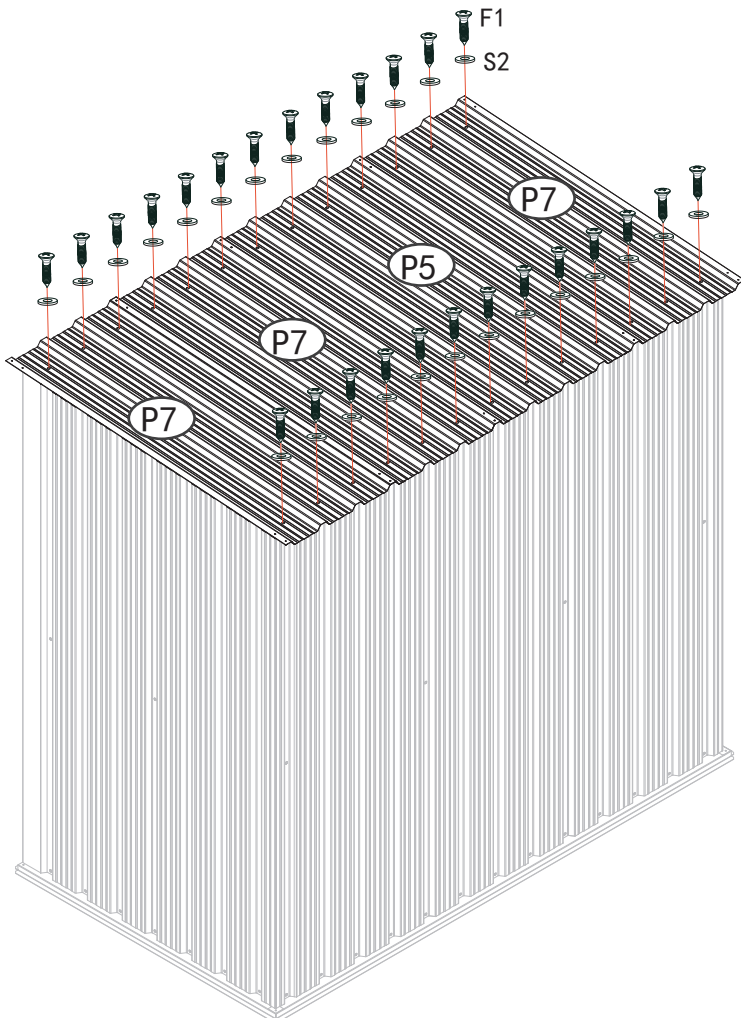
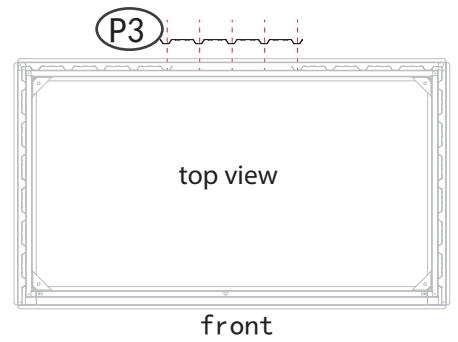

Parts	No.	Qty.
	P5	1
	P7	3
	F1	26
	S2	26

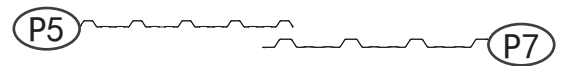

The two small holes should coincide

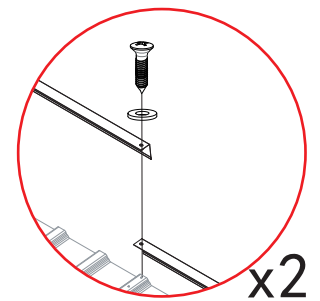
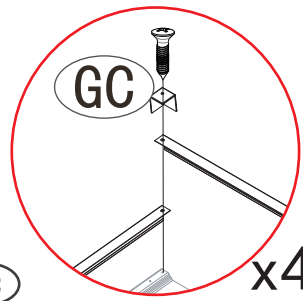
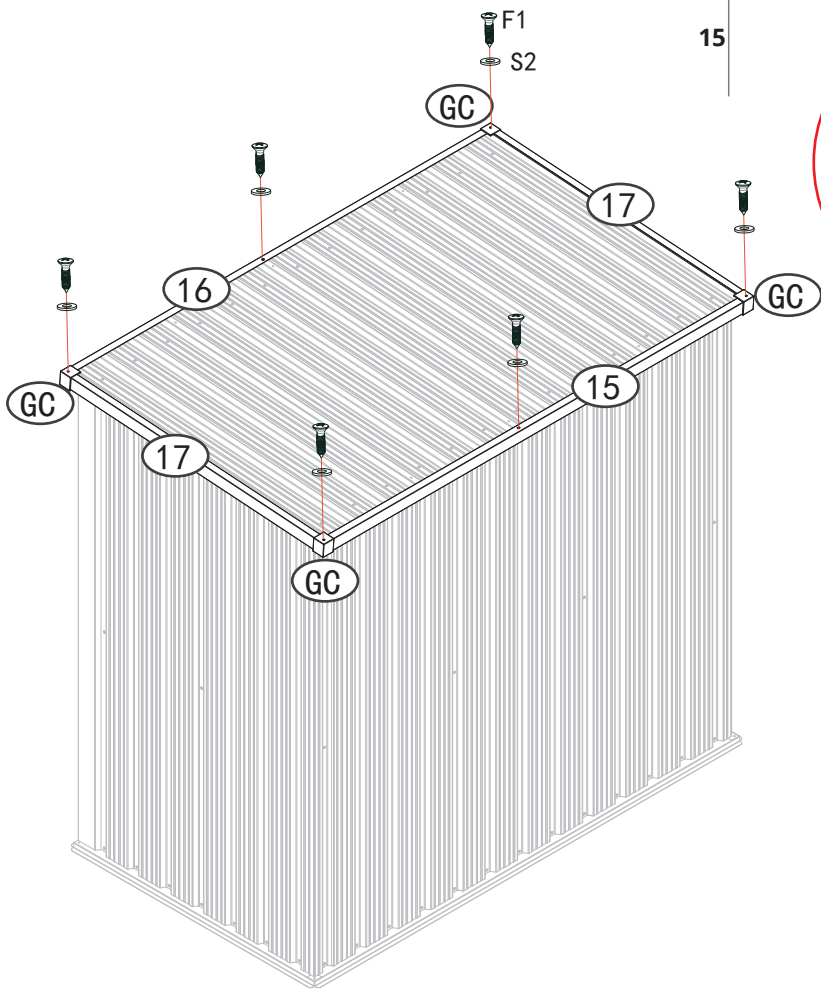



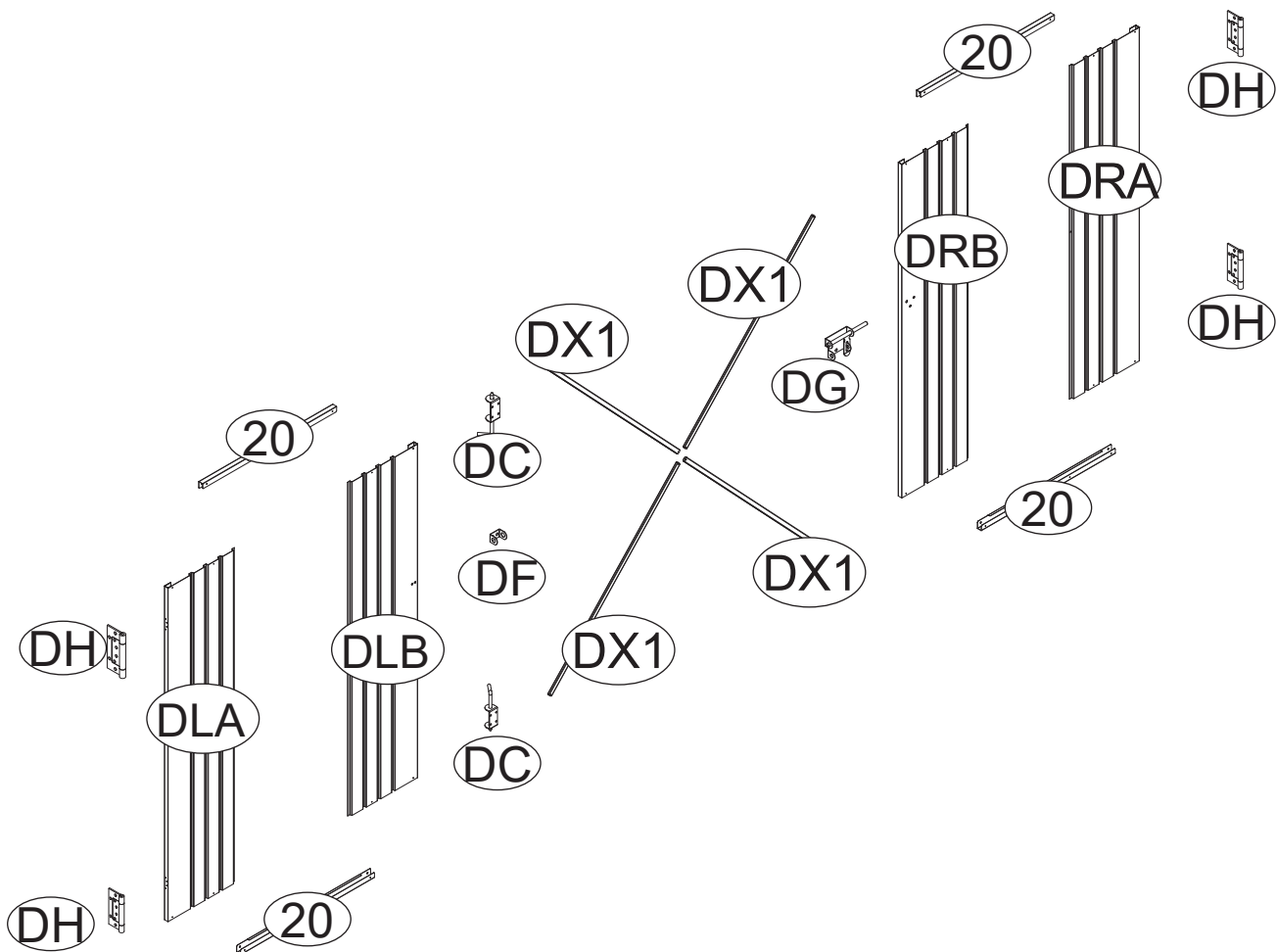

NO.	PART	Qty.
15		1
16		1
17		2
GC		4
F1		6
S2		6

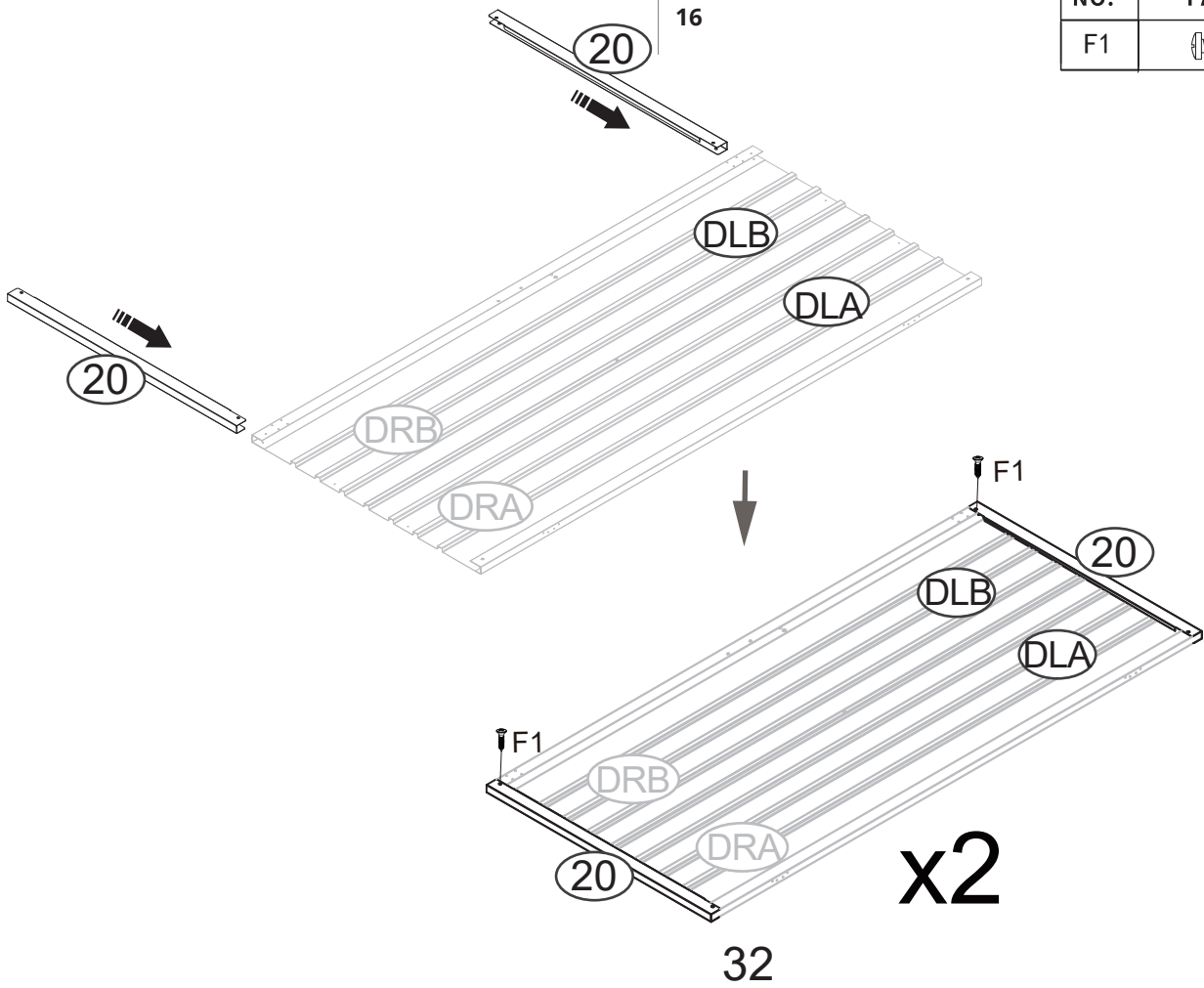

NO.	PART	Qty.
F1		2



PART	NO.	Qty.
	F4	2
	F1	22
	F3	8
	S2	9

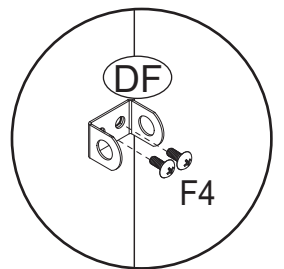
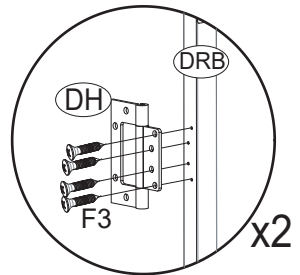
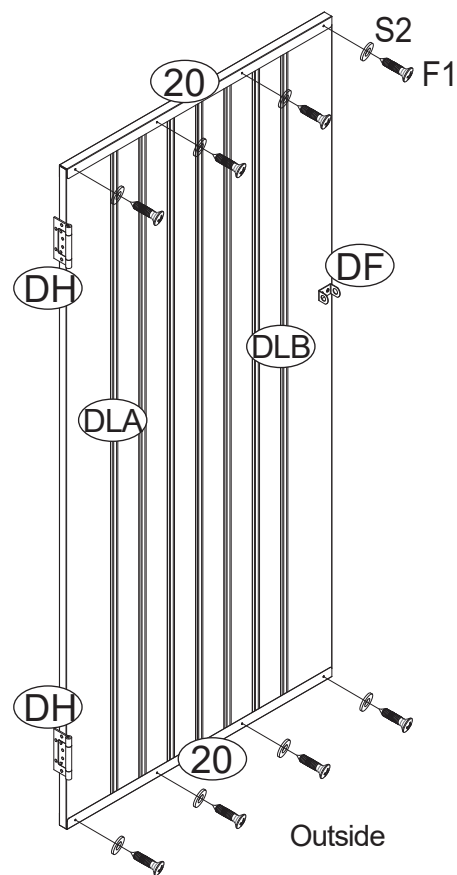
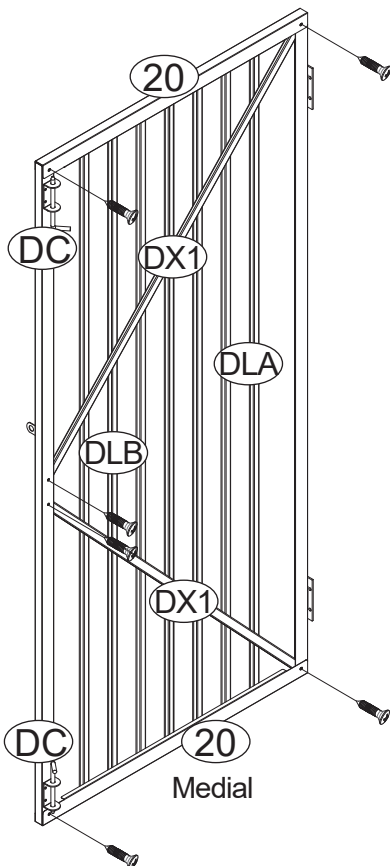
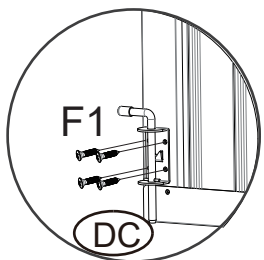
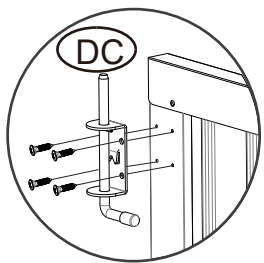

PART	NO.	Qty.
	F2	1
	F4	3
	F1	14
	F3	8
	S2	9

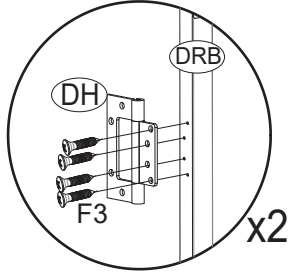

x2

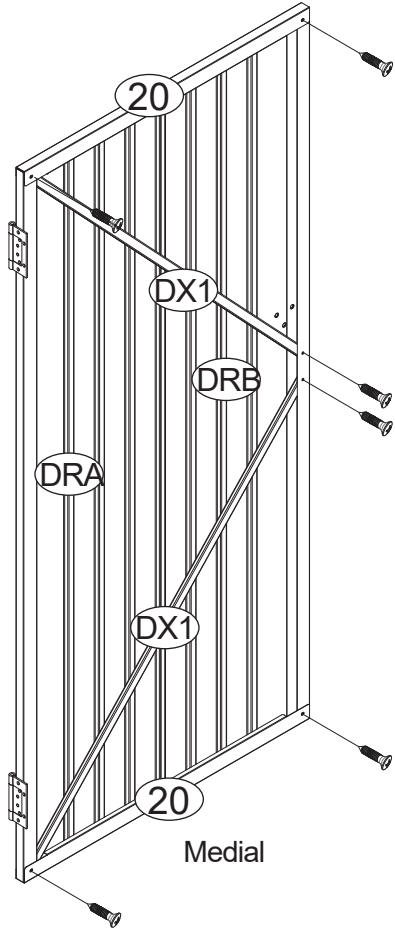

Medial

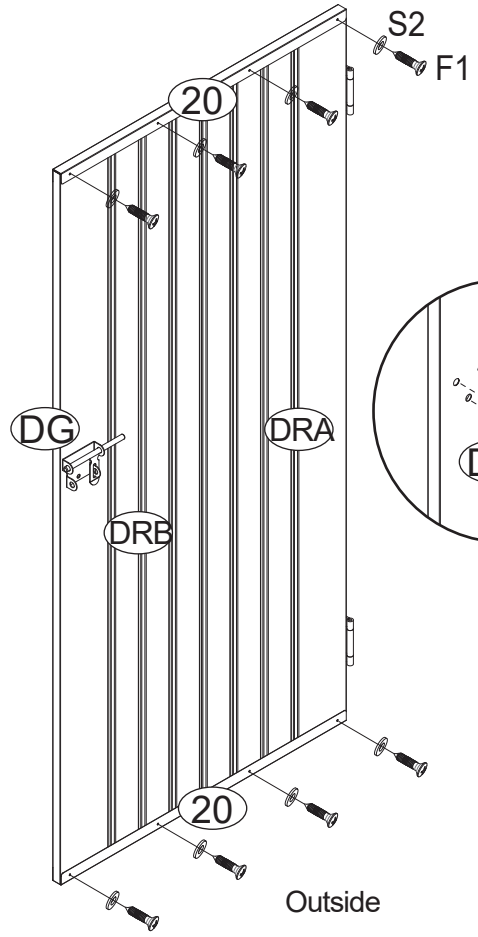

Outside

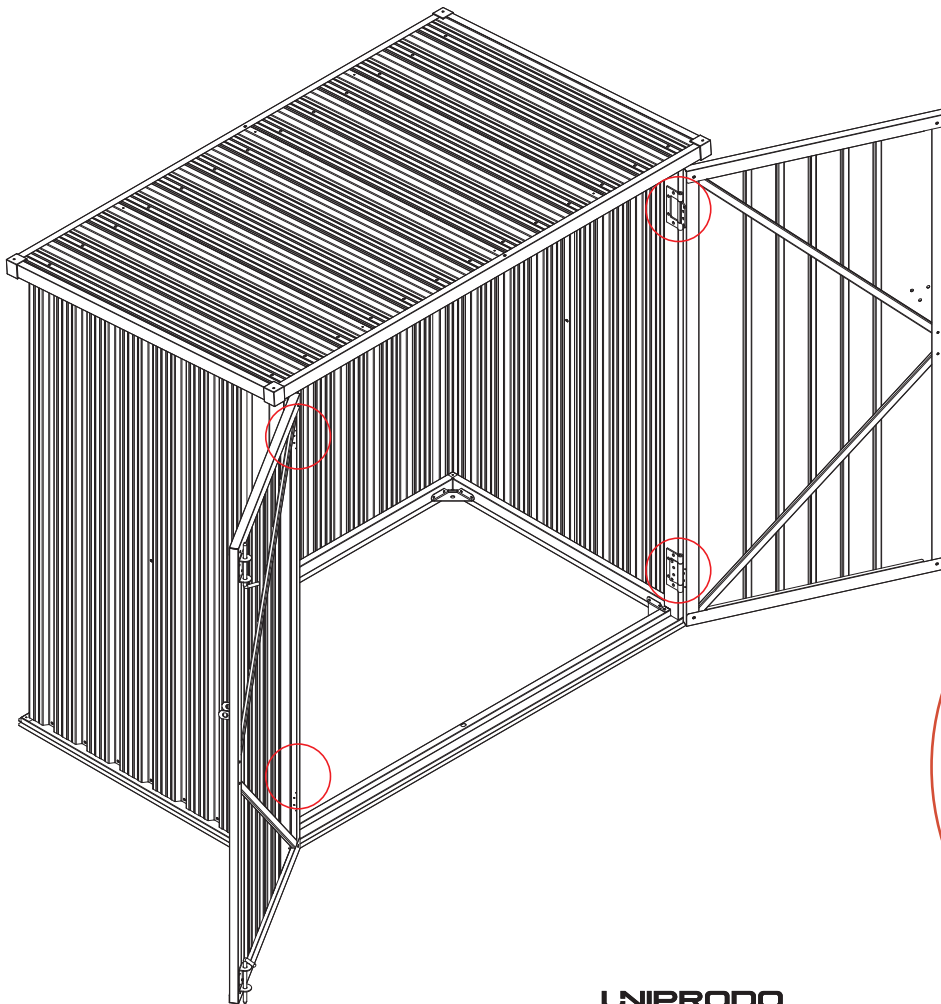
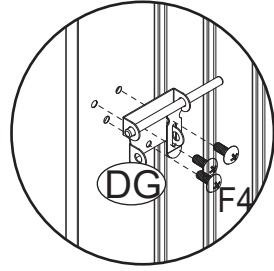

NO.	PART	Qty.
F3		16

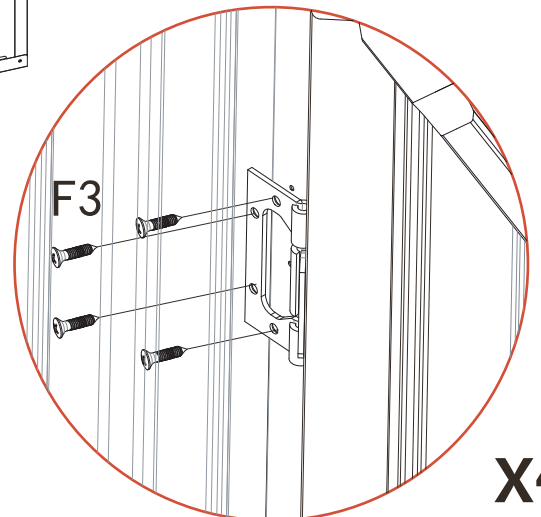

x4

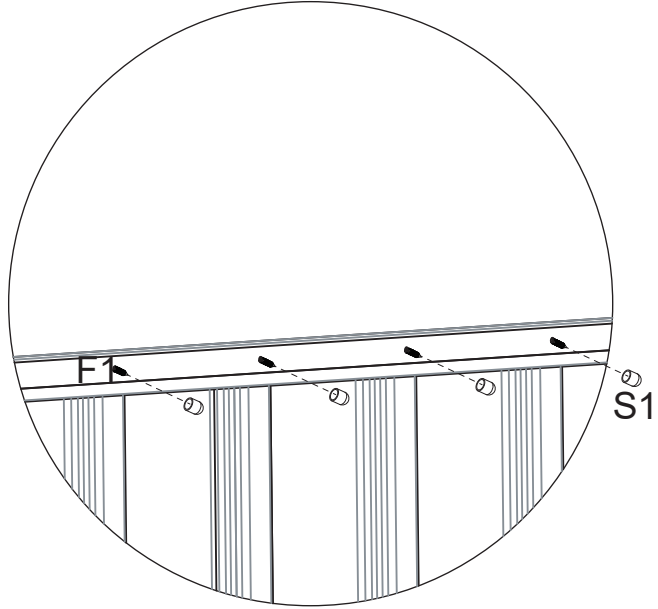
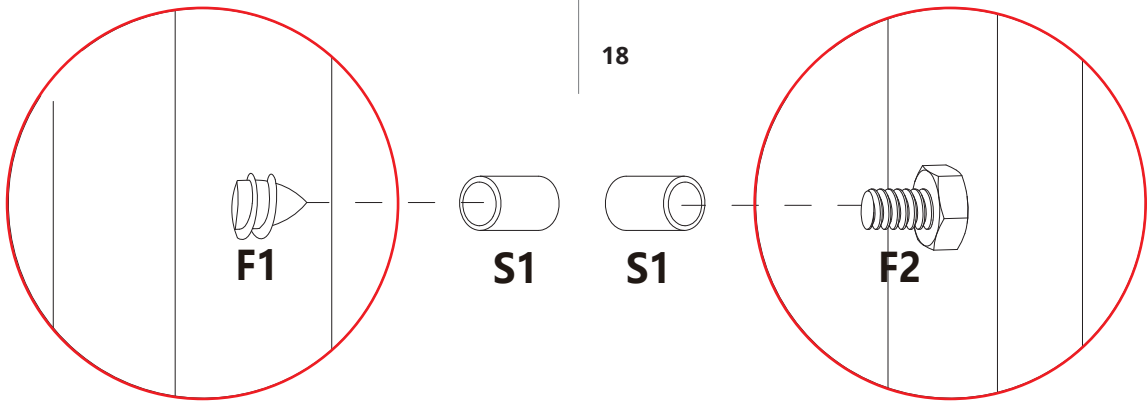





































NO.	PART	Qty.
S1		50





MODEL BEFORE 2025

ASSEMBLING THE EQUIPMENT | SKŁADANIE SPRZĘTU

NO.	PART	Qty.
1	 752mm	2
2	 1394mm	1
3	 1394mm	1
9	 724mm	2
10	 1354mm	1
35	 747mm	4
30	 582mm	4
31	 1252mm	2
32	 1252mm	1
33	 1252mm	1
34	 1164mm	1
17	 1460mm	2
15	 852mm	2
4L	 1300mm	1
4R	 1300mm	1
6	 1301mm	1
36	 1	1
J2	 4	4

NO.	PART	Qty.
P1	 1300mm	1
P2	 1300mm	1
P3	 1250mm	1
P4	 1250mm	1
P5	 1195mm	3
P6	 852mm	3
D1	 1252mm	2
G6	 2	2
G8	 1	1
G7	 1	1
G9	 1	1
G3	 4	4
J1	 4	4
GC	 4	4
F1	 160	160
F2	 42	42
F3	 16	16
S2	 40	40
S3	 144	144

NO.	PART	Qty.	NO.	PART	Qty.
1		2	2		1
3		1			

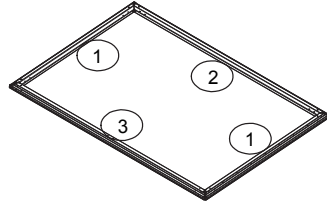
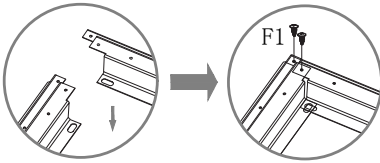

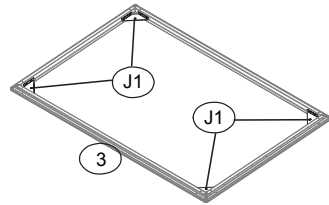
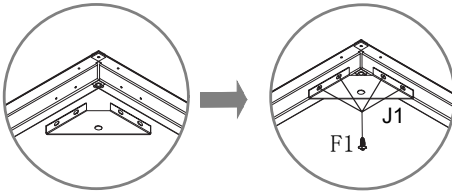

NO.	PART	Qty.
J1		4



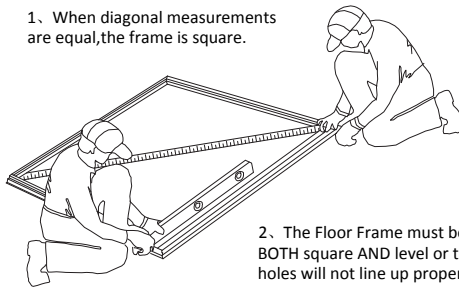

1. When diagonal measurements are equal, the frame is square.

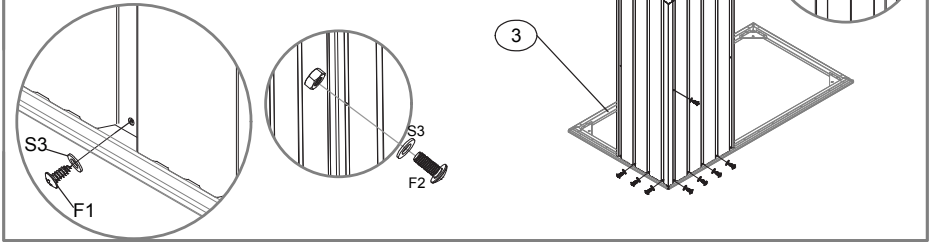

2. The Floor Frame must be BOTH square AND level or the holes will not line up properly.

NO.	PART	Qty.
P3		1
P5		1



NO.	PART	Qty.
P4		1
P5		1

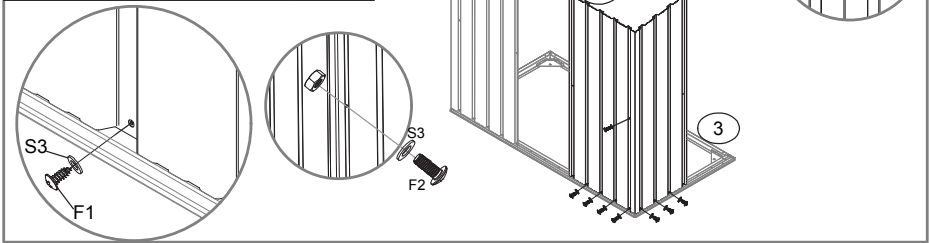

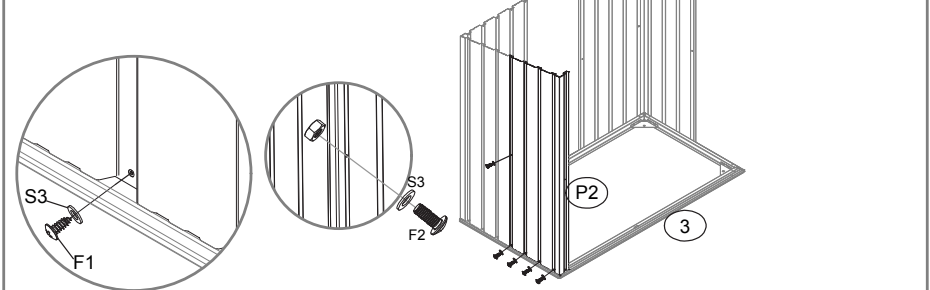

NO.	PART	Qty.
P2		1

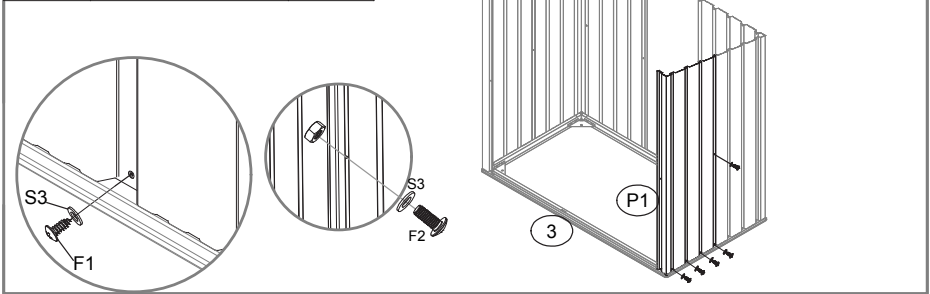

NO.	PART	Qty.
P1		1



NO.	PART	Qty.
4L		1
4R		1

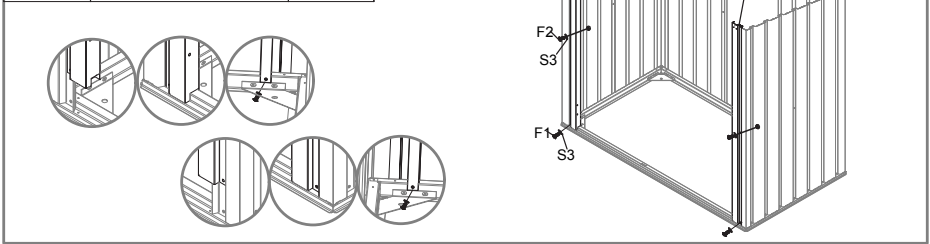

NO.	PART	Qty.
10		1

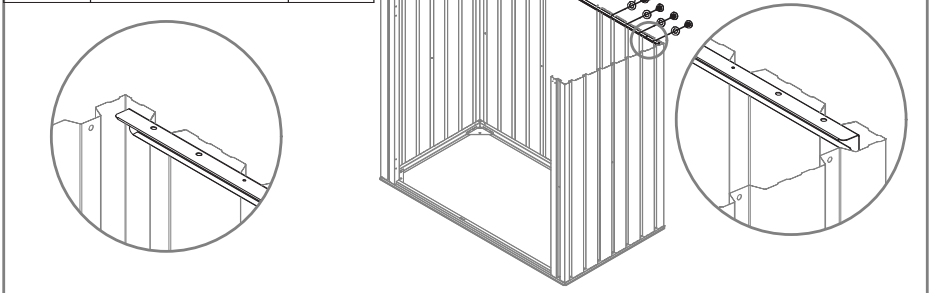

NO.	PART	Qty.
9		2

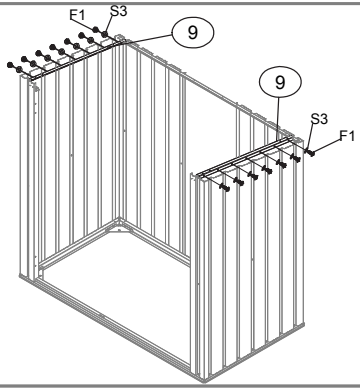

NO.	PART	Qty.
6		1

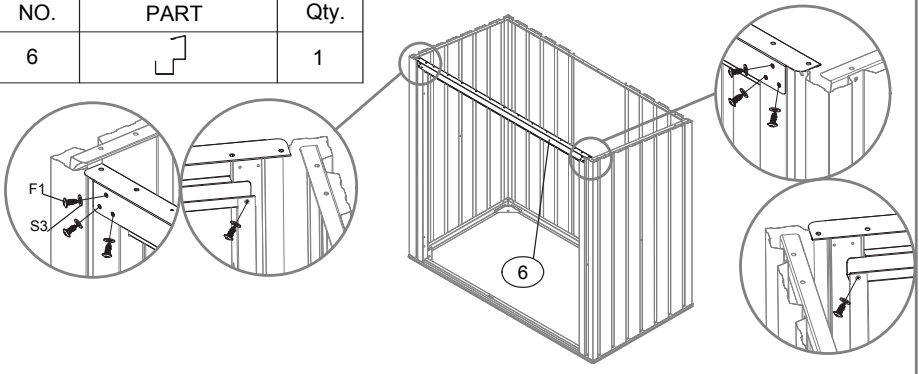

NO.	PART	Qty.
J2		4

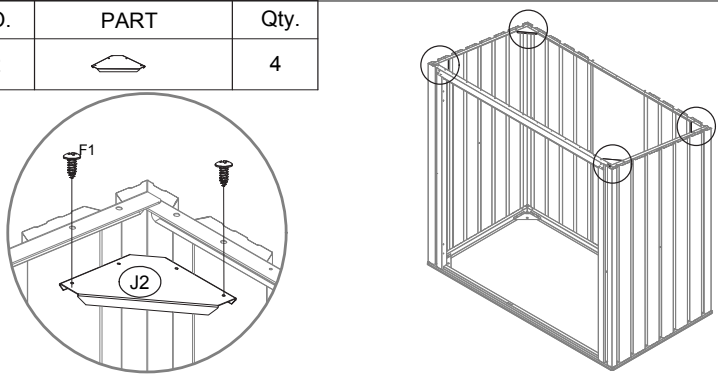

NO.	PART	Qty.
P5		1

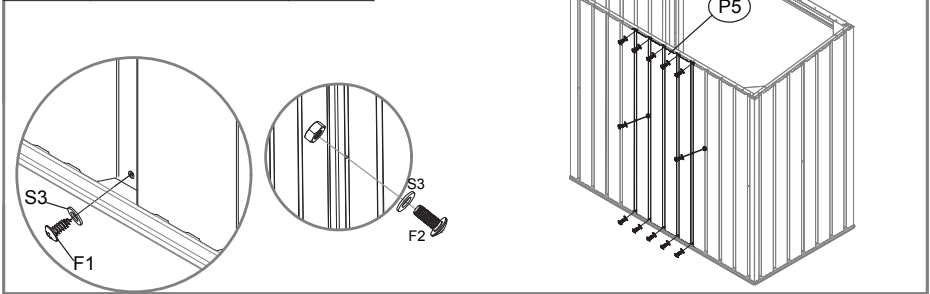

NO.	PART	Qty.
P6		3

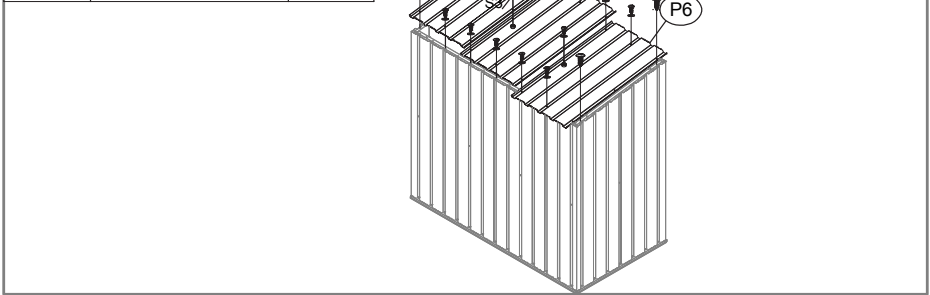

NO.	PART	Qty.
15		2

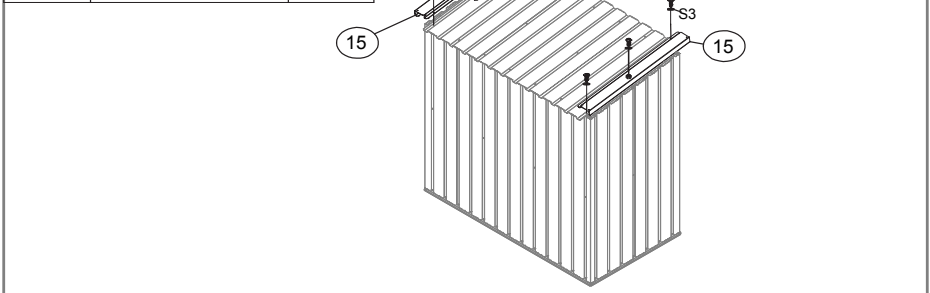

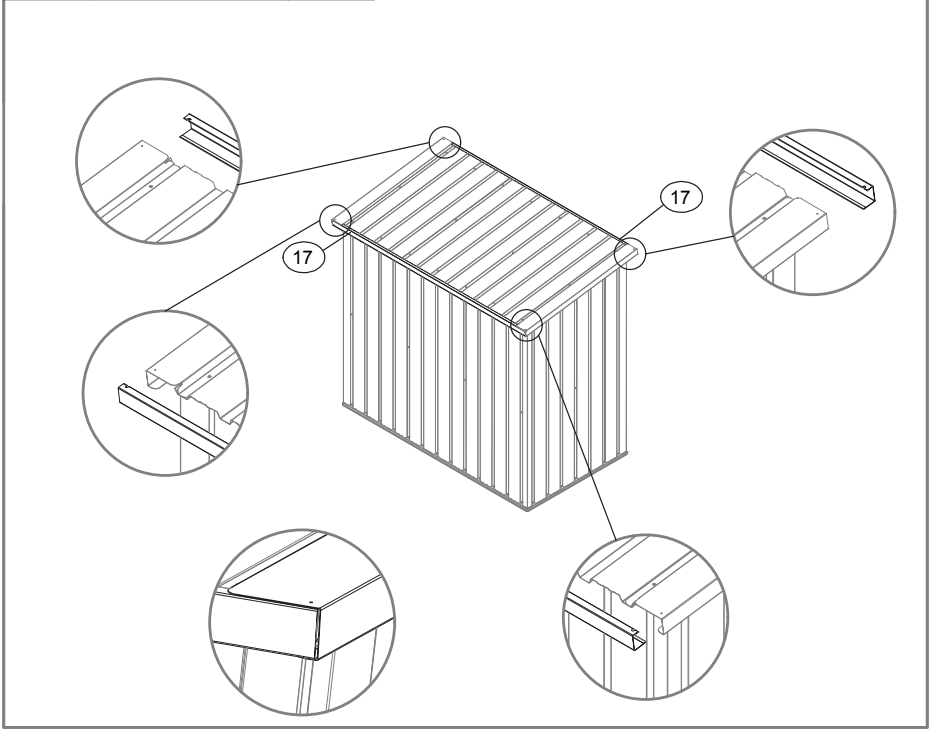

NO.	PART	Qty.
17		2



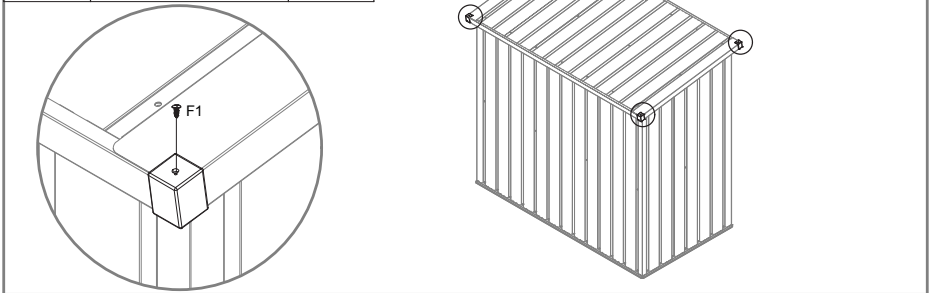

NO.	PART	Qty.
GC		4



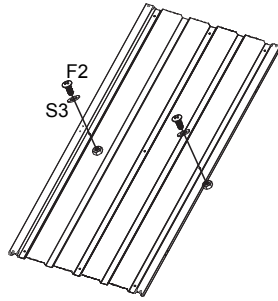
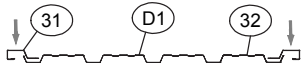



NO.	PART	Qty.
D1		1
31		1
32		1

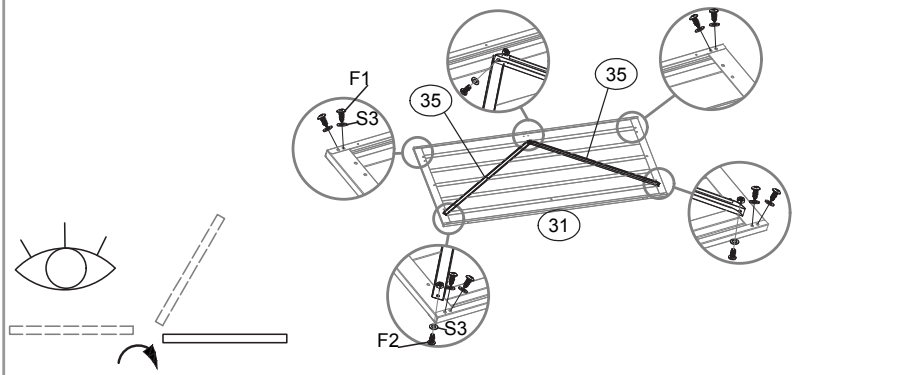
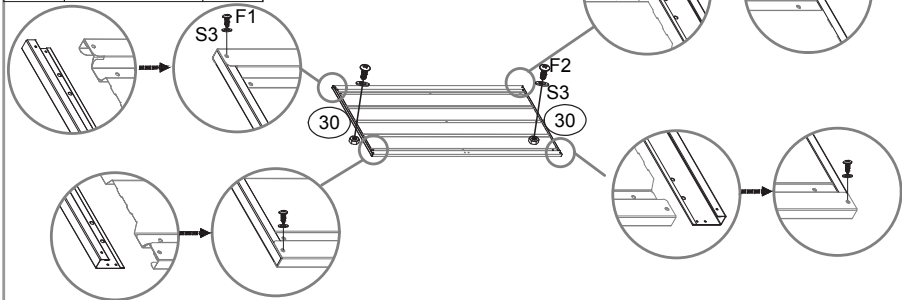

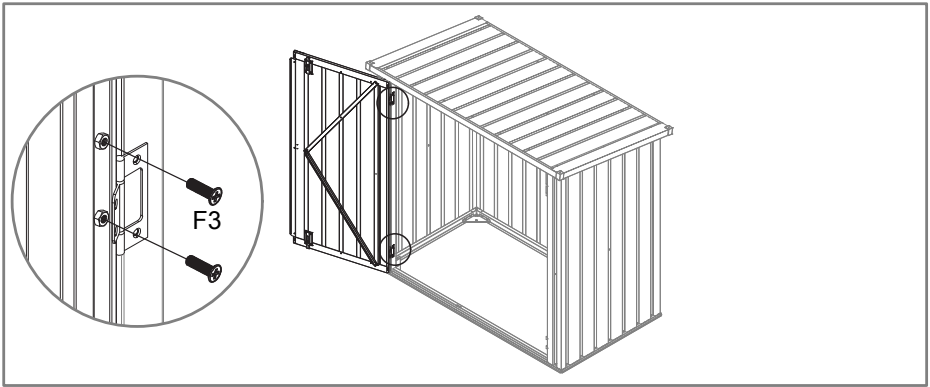
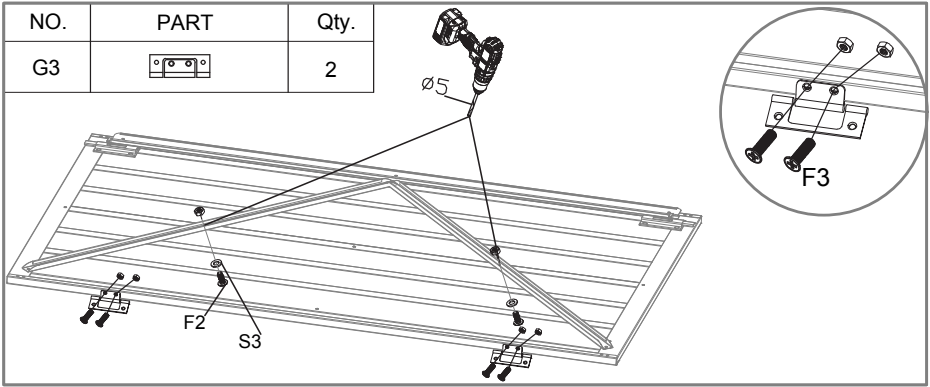
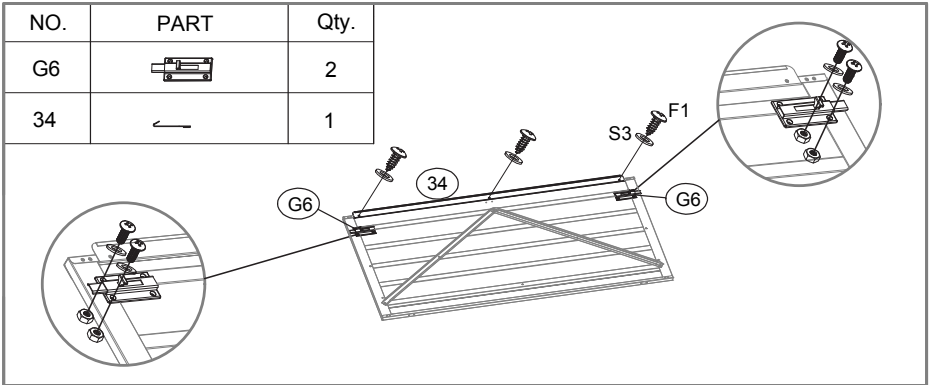

NO.	PART	Qty.
30		2
35		2



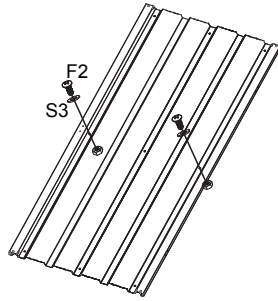
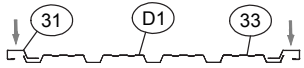

NO.	PART	Qty.
D1		1
31		1
33		1



NO.	PART	Qty.
30		2
35		2

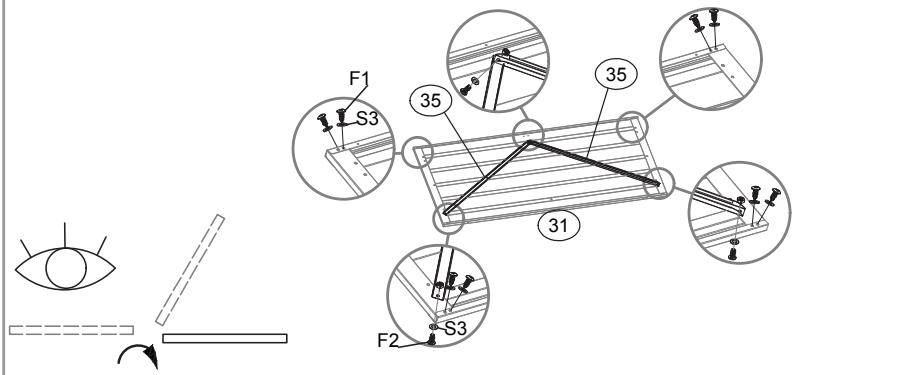
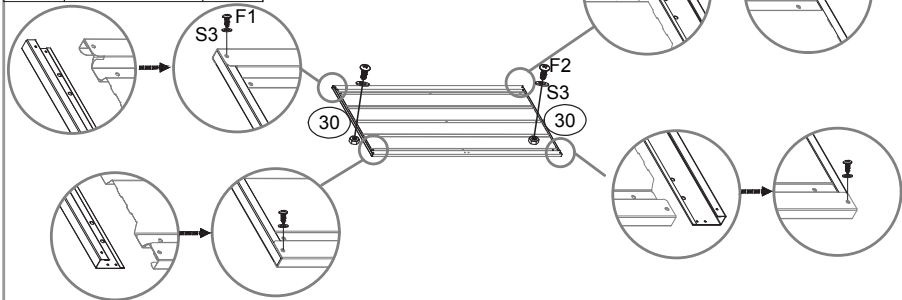

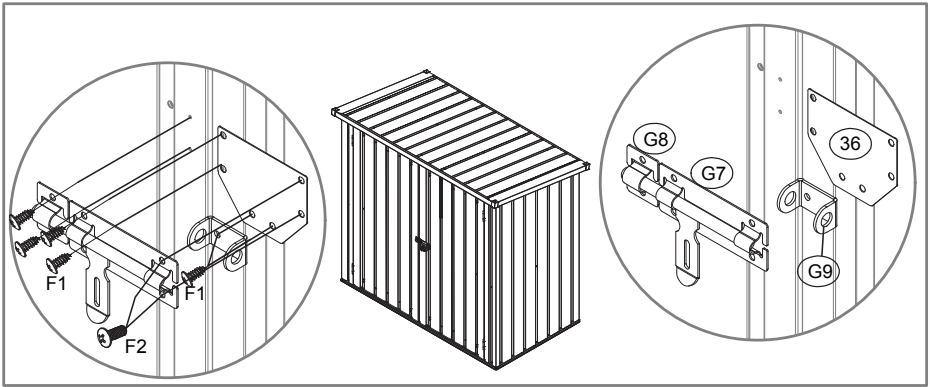
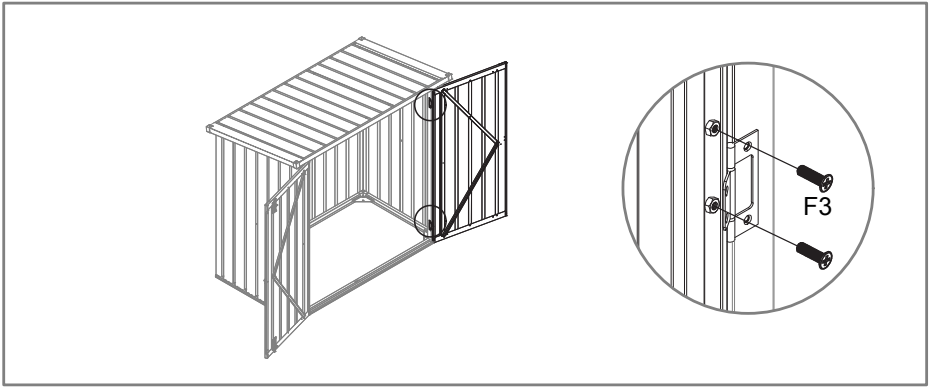
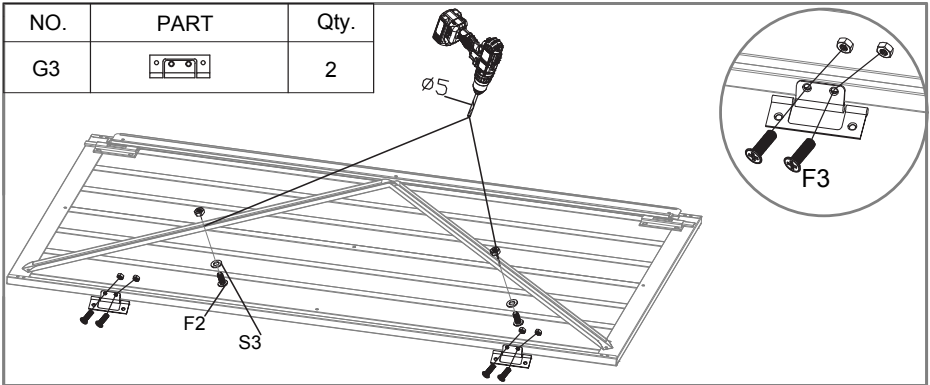

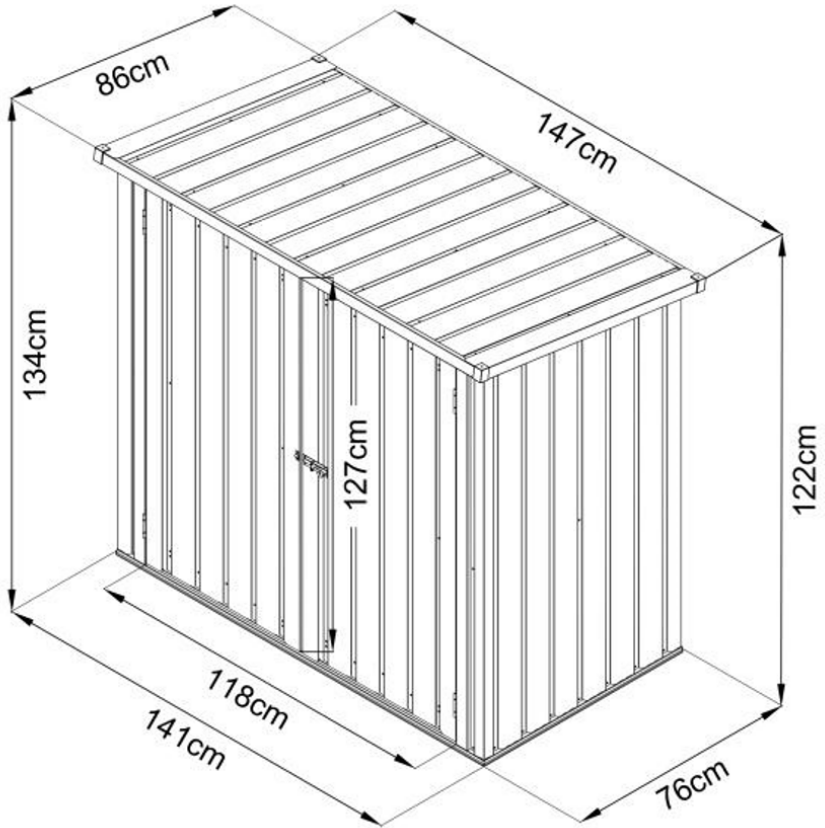

Umwelt – und Entsorgungshinweise

Hersteller an Verbraucher

Sehr geehrte Damen und Herren,

gebrauchte Elektro – und Elektronikgeräte dürfen gemäß europäischer Vorgaben **[1]** nicht zum unsortierten Siedlungsabfall gegeben werden, sondern müssen getrennt erfasst werden. Das Symbol der Abfalltonne auf Rädern weist auf die Notwendigkeit der getrennten Sammlung hin. Helfen auch Sie mit beim Umweltschutz. Sorgen Sie dafür, dieses Gerät, wenn Sie es nicht mehr weiter nutzen wollen, in die hierfür vorgesehenen Systeme der Getrenntsammlung zu geben.



In Deutschland sind Sie gesetzlich **[2]** verpflichtet, ein Altgerät einer vom unsortierten Siedlungsabfall getrennten Erfassung zuzuführen. Die öffentlich – rechtlichen Entsorgungsträger (Kommunen) haben hierzu Sammelstellen eingerichtet, an denen Altgeräte aus privaten Haushalten ihres Gebietes für Sie kostenfrei entgegengenommen werden. Möglicherweise holen die rechtlichen Entsorgungsträger die Altgeräte auch bei den privaten Haushalten ab.

Bitte informieren Sie sich über Ihren lokalen Abfallkalender oder bei Ihrer Stadt – oder Gemeindeverwaltung über die in Ihrem Gebiet zur Verfügung stehenden Möglichkeiten der Rückgabe oder Sammlung von Altgeräten.

[1] RICHTLINIE 2002/96/EG DES EUROPÄISCHEN PARLAMENTS UND DES RATES
ÜBER ELEKTRO – UND ELEKTRONIK – ALTGERÄTE

[2] Gesetz über das Inverkehrbringen, die Rücknahme und die umweltverträgliche Entsorgung von Elektro – und Elektronikgeräten (Elektro – und Elektronikgerätegesetz – ElektroG).

Utylizacja produktu

Produkty elektryczne i elektroniczne po zakończeniu okresu eksploatacji wymagają segregacji i oddania ich do wyznaczonego punktu odbioru. Nie wolno wyrzucać produktów elektrycznych razem z odpadami gospodarstwa domowego. Zgodnie z dyrektywą WEEE 2012/19/UE obowiązującą w Unii Europejskiej, urządzenia elektryczne i elektroniczne wymagają segregacji i utylizacji w wyznaczonych miejscach. Dbając o prawidłową utylizację, przyczyniasz się do ochrony zasobów naturalnych i zmniejszasz negatywny wpływ oddziaływania na środowisko, człowieka i otoczenie. Zgodnie z krajowym prawodawstwem, nieprawidłowe usuwanie odpadów elektrycznych i elektronicznych może być karane!

For the disposal of the device please consider and act according to the national and local rules and regulations.

CONTACT

expondo Polska sp. z o.o. sp. k.

ul. Nowy Kisielin-Innowacyjna 7
66-002 Zielona Góra | Poland, EU

e-mail: info@expondo.com

